

# UNIOR® Automotive tools 2017

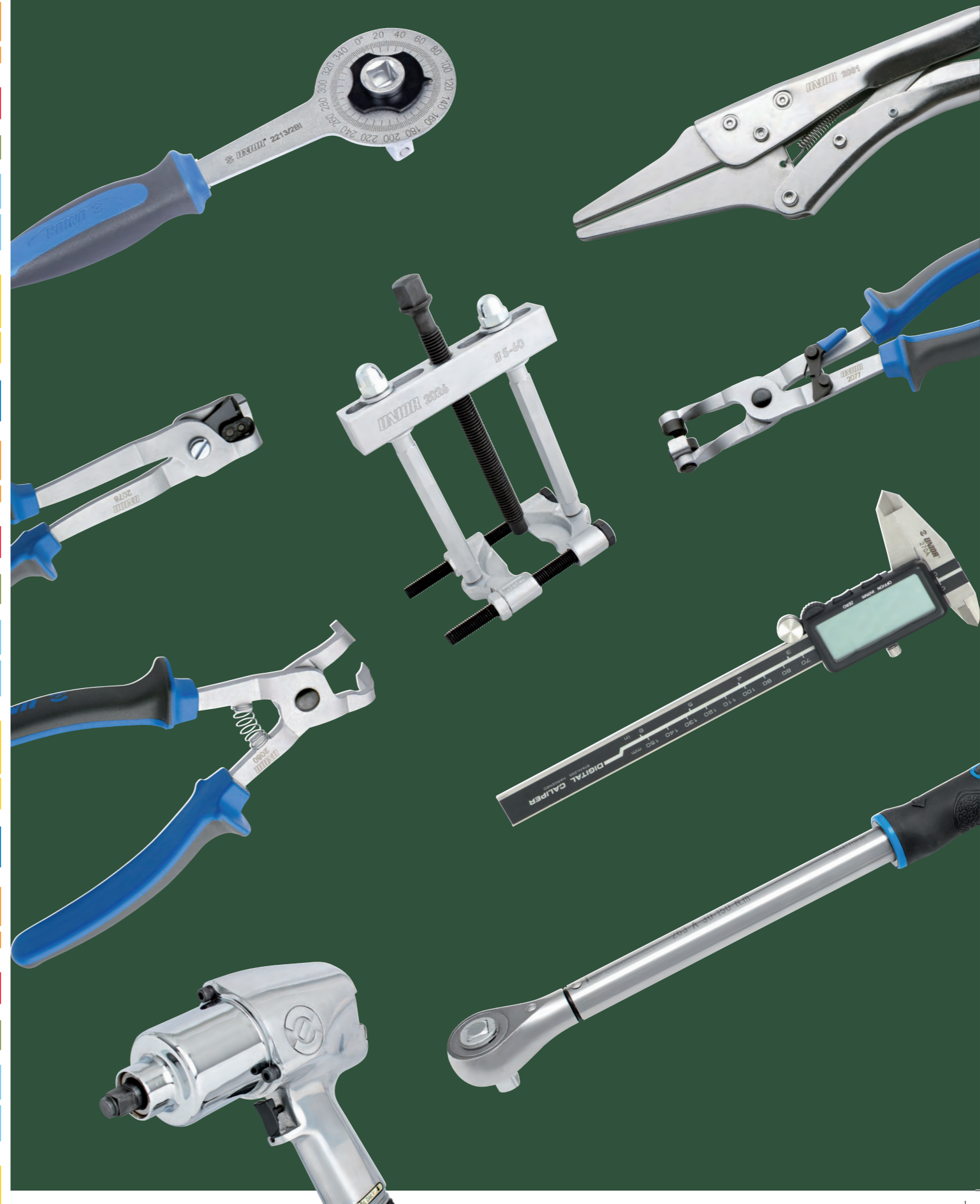

**UNIOR d.d.**  
 Kovaška cesta 10  
 3214 ZREČE, Slovenia  
 T: +386 3 757 81 00  
 F: +386 3 576 26 43  
 sales@unior.si  
 www.uniortools.com



<b>Tool for maintenance</b>	<b>A</b>
<b>Tools for lubrication and filtration</b>	<b>B</b>
<b>Bodywork tools</b>	<b>C</b>
<b>Tools for wheels, steering and hubs</b>	<b>D</b>
<b>Suspension and transmission tools</b>	<b>E</b>
<b>Auto electricity tools</b>	<b>F</b>
<b>Tools for engine</b>	<b>G</b>
<b>Sets</b>	<b>H</b>
<b>Torque wrenches</b>	<b>I</b>
<b>Pneumatic tools</b>	<b>J</b>
<b>Pneumatic accessories</b>	<b>K</b>
<b>Vices</b>	<b>L</b>

# UNIOR GROUP

## European Partner of Excellence

Unior is an internationally renowned company with a reputation for top expertise in the field of metalworking. With its own development, Unior has secured itself the position of a renowned supplier to the automotive industry. With an exceptional tradition of smithery and



## FORGING PARTS

### Certified Quality

By drop forging steel and machining, we make forging parts for control mechanisms and gearboxes, supporting parts of chassis, components for drive shafts and sinter forging parts for the most renowned European and global makers of vehicles: VW, Audi, Renault, Dacia, BMW, ZF Lemförder & ZF Lenksysteme, Jtekt, GKN, Arvin Meritor, BPW, Schäffler KG, Betek and Cimos. Various certificates, tests and awards for excellence confirm the quality of forging parts made in Unior.

### Developmental Supplier

With its highest quality sintered parts, Unior is classified among the most important suppliers to the systemic automotive industry. Products made by Unior are built into the steering wheel assemblies and gear mechanisms of prestigious makes of cars such as BMW, Audi, VW and Volvo. Unior also provides parts for fittings, sliders, rotors, casings for oil pumps, self-lubricating bearings and sleeves, stators and rotors for electric motors, gears, belt pulleys, connecting rods and flanges etc.

with the original design of quality tools, the company has been an ally to both amateur and professional master craftsmen. Due to its comprehensive understanding of technological processes, Unior is an excellent partner in developing solutions for automatic metalworking.



[www.rogla.eu](http://www.rogla.eu)  
[www.term-zrece.eu](http://www.term-zrece.eu)

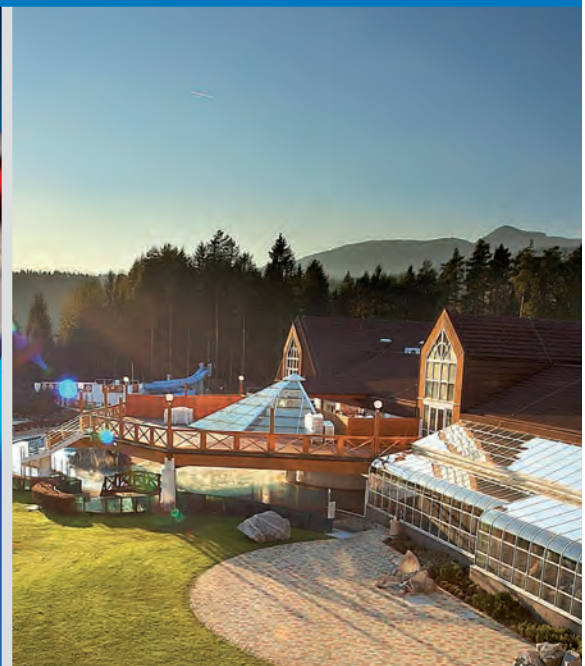

## SPECIAL MACHINES

### **Automatic Metalworking**

Unior mechanical equipment provides comprehensive solutions, ranging from the concept stage to the finished product. Beside specific CNC machine tools for the serial working of aluminium castings or forging parts, Unior also offers flexible production cells, machines for deep hole drilling, for working ends and for working chassis parts, machines with a rotary table and special purpose machines. Unior is a supplier of machines for renowned car manufacturers such as VW, BMW, Audi, Daimler etc.

## HAND TOOLS

### **The Right Brand for Craftsmen**

The development of Unior hand tools constantly follows the requirements of professional and amateur craftsmen all over the world. Top quality materials and original design solutions are the basis of the extreme practicality, effectiveness and long service life of more than 5,500 hand tools. The availability of tools is ensured by a multi branch distribution network. With its cold forged products, Unior is an important supplier of tools for the European industry.

## TOURISM

### **Relaxation Surrounded by Nature**

Unior, which operates in the shelter of the Pohorje mountain range, surrounded by an attractive landscape, is developing two interrelated tourist centres. The Rogla climatic health resort, Olympic centre and winter sports centre is especially interesting for professional athletes and recreational athletes, while the Terme Zreče spa is ideal for those seeking health and wellbeing. Both connected health resorts with their modern capabilities are an excellent choice for family holidays, health rehabilitation and preparation for top athletes.

**ŠTORE STEEL**  
Co-owner of  
the steelworks  
material: chrome  
vanadium rods

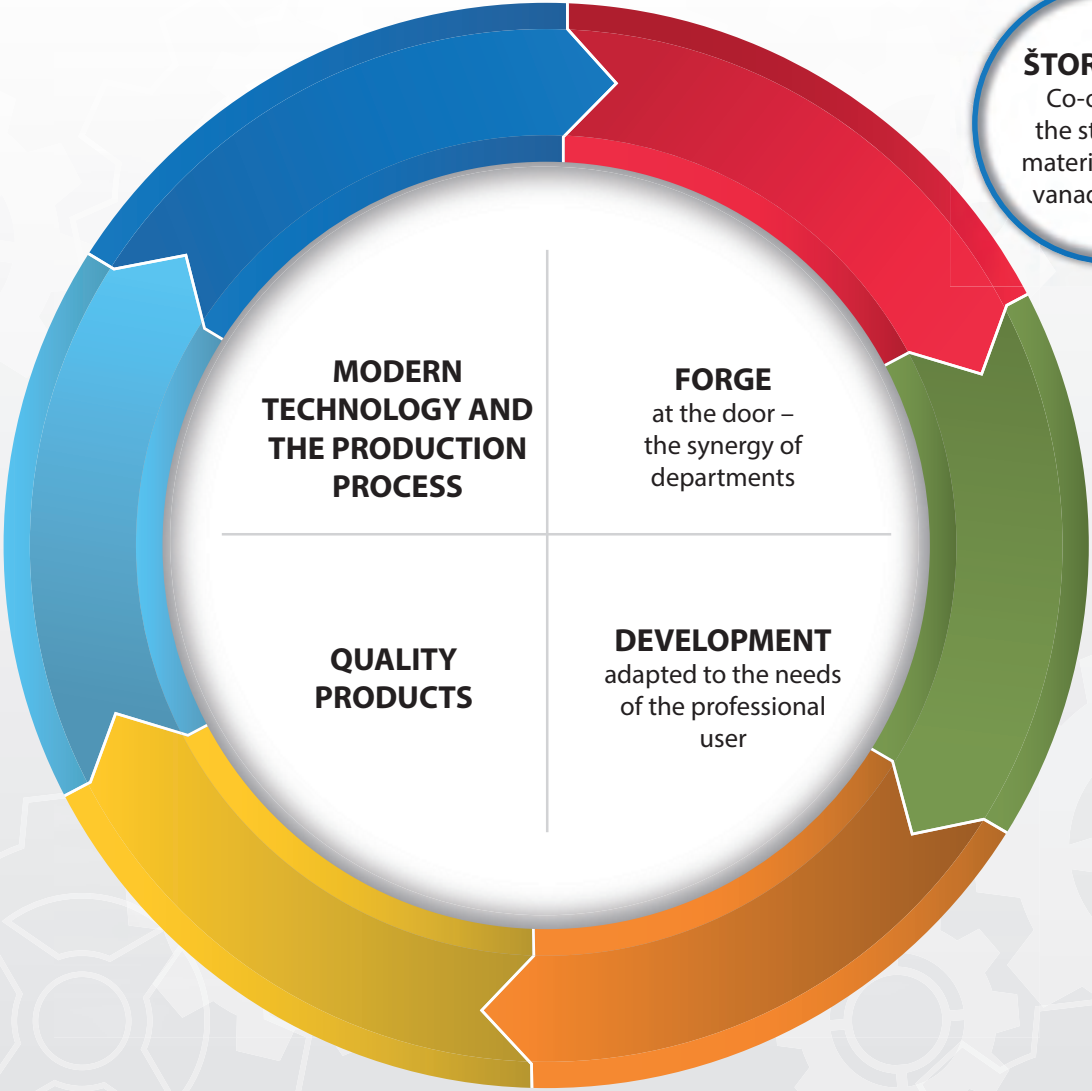

**PARTNERSHIP**

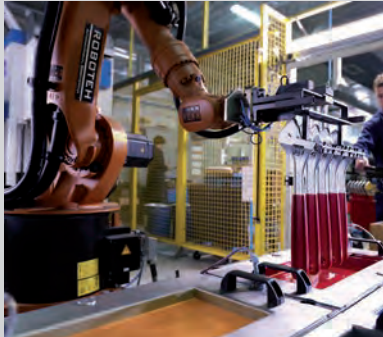
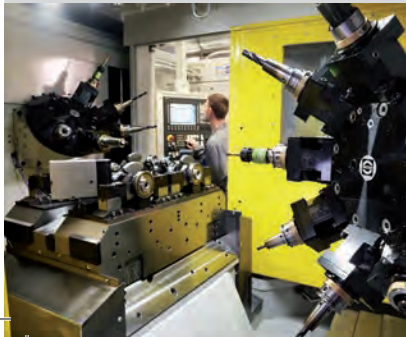
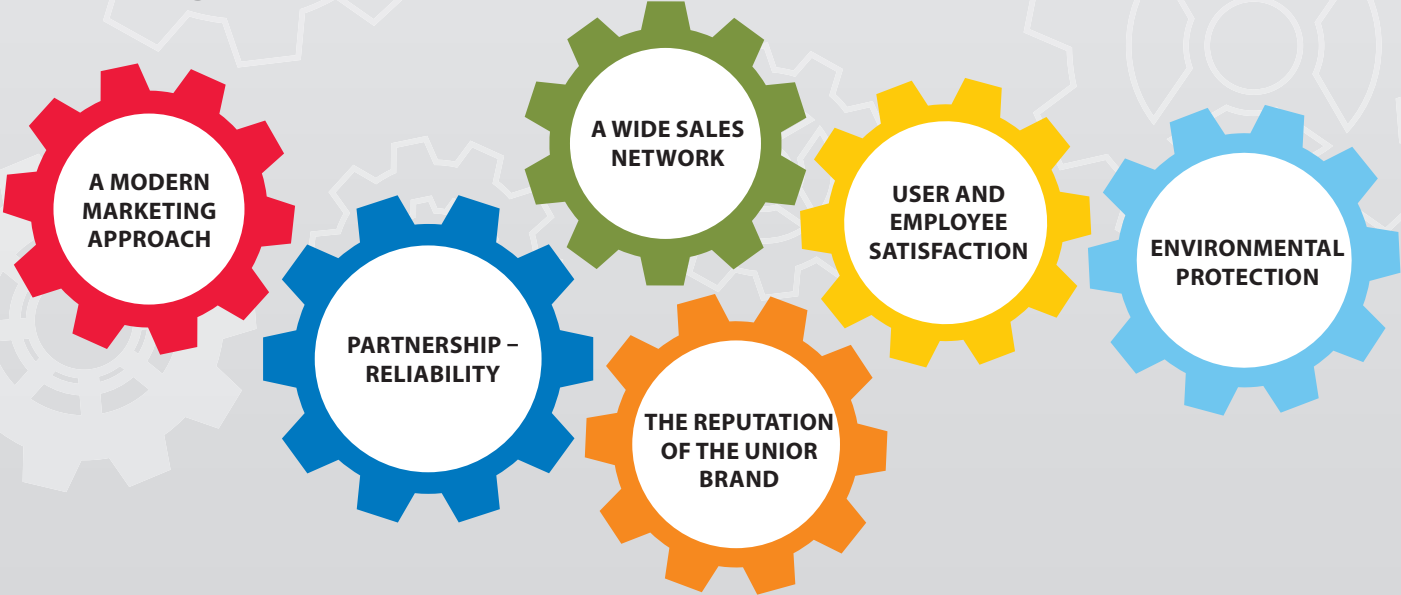

### Our own development

Partnership is crucial when you need to be competitive in your market (industry, aerospace, railway, automotive field)

### Optimising your supply chain budgets

Special relations for specific challenges our production enables best price for our partners

**PRODUCT WITH  
ADDED VALUE**

**ERGONOMICS**

**Constant quality**

**3 time longer life  
Durability  
Lifetime guarantee**

## ADVANTAGES FOR PROFESSIONAL USERS:



**Cost-effectiveness** provides at least 3 times longer tool life Unior compared with some other standard tools.



**Perfection of Unior tools** is reflected in the perfect fit to the workpiece. There is no slippage or damage.



**Optimum construction of Unior tools** ensures long-term durability and endurance, which means more profitability.



Unior tools are designed and produced with the perfect relationship between quality and price, ensuring profitability to the user.



**The ergonomic design of Unior tools** requires less physical effort.



**Development partnership** solve specific problems through the development of dedicated tools at the user's request.



**Functionality of Unior tools** expressed through greater efficiency at work.



Flexibility and control of Unior processes is reflected in the quick response to the customer.



**Development of tools** added value provides greater user productivity.

# Milestones of the Unior corporation

## From Styria to the world

On the outskirts of the Pohorje Mountains, the first ironworks (foundries) were established in the 18th century. They operated as larger forges, in which land and tradesmen's tools were fashioned by hand.

1919

In 1919 the Štajerska železindustrijska družba (Styrian Iron Industry Company) forging plant, with the shortened name Štajerska Zrece, was established. It produced forged hand tools for farming, forestry and various other trades.

1970

In the 1970s the plant equipped with a new development strategy also obtained a new name: Unior, tovarna kovanega orodja Zrece. The new name was formed from the words "Univerzalno Orodje" (Universal Tools), by which the company had been known for a long time.



In 1950 the plant, burned down during the war and partially renovated in the years following the war and bearing the new name of Tovarna kovanega orodja Zrece (TKO) came under state ownership. New capacities (tool shop and hand tools mechanical processing plant) comprised the basis for developing two production lines: hand tools and drop forgings.

1950



## Infinite enthusiasm gives us the strength to reach milestones

Through permanent development while realising the necessity of changes and a competitive advantage we are consistently taking on new challenges with regard to all activities of the company thus ensuring successful operations.

1975

In the mid-1970s Unior began building the Rogla climatic health resort and Olympic centre on Pohorje, and a few years later construction of the Terme Zreče spa commenced and with it, the Tourism Programme.

1997

In 1997 this successful Slovenian company with stable international partnerships was transformed into the UNIOR, d. d. joint stock company. Already at that time, the company had been operating in accordance with ISO 9001 quality standards.



By the 1980s Unior had established its name as an important partner of the European automotive industry, namely as one of the largest European producers of light forgings and as one of the largest European producers of connecting rods for petrol engines. Initial development was enabled by a contract with the Renault concern, on the basis of which a joint-venture plant for the production of forgings was built in Zreče. At the same time, Unior developed its production of homokinetic joints and machine tools, initially intended for the company's own needs.

1980

2017

Unior Joint-Stock Company is today one of the largest and most important Slovenian exporters. With its five production segments company follows the tradition of a high quality and innovation. Committed to high utilization of own capacities, Unior enhances the brand awareness through more than 2400 employees and 32 group companies around the world.

## EUROVISION tool carriages are available in the following colours:



blue



orange



red



green



black



white



anthracite grey



grey

### Advantages

- Design your carriage to match the colour of your workshop.
- If you choose a special colour for each drawer, you will always know exactly what is inside.
- Additional motivation for employees.

### Colour combinations available for:

The only carriage in the production program of Unior that is exclusively intended for use by the private consumer.





## SOS tool tray

- We can produce SOS tool trays according to your needs and wishes.
- Tell us your wishes and we will prepare an offer for you.
- The trays are available with a thickness of 2, 3 and 4 cm.
- In a blue/black colour combination.
- Your tool carriage will never be untidy again.
- The drawers only contain the tools that you need.
- 100% neatly organised.
- You will immediately spot if something is missing.
- Quality design guarantees long-term use
- For extra-demanding work.



**Unior creates for you solution on safety use of tools for working at height and also solution with RFID technology, where are control and traceability necessary.**

## 2076/1

### Roller-type stud extractor

- material: chrome vanadium
- surface finish: chrome plated according to EN12540
- polished

#### Advantages:

- roller system grips on to stud, in both directions
- easy extraction of studs

#### How to use the tool:

1. Position roller-type stud extractor on stud
2. START turning stud extractor COUNTER CLOCK wise
3. When stud removed, simply pull down stud extractor

#### Important!

- Do not use roller-type stud extractor for tightening!
- Studs are screws without a surface that can be gripped, which prevents their removal without damaging them. This tool is intended to do exactly that – removing studs without damaging the threads. The tool works through a system of three rollers that grip the stud at three points during removal, removing the stud without damaging it. The three rollers have no sharp edges, enabling removal without causing damage as they. Despite this, the tool can work in both directions. Tightening with the tool is not recommended though as the increased force in tightening could damage the system of rollers, which are dimensioned solely for loosening.

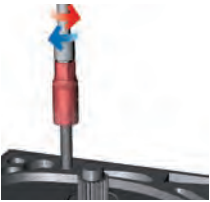

	L	D							
619238	M 5	60	21.5	19	3/8"	-	133	4B	10
619239	M 6	60	23.5	21	1/2"	-	134	4B	10
619240	M 7	60	23.5	21	1/2"	-	131	4B	10
619241	M 8	60	23.5	21	1/2"	-	128	4B	10
619242	M 10	69	27.5	21	1/2"	-	186	4B	10
619243	M 12	69	27.5	21	1/2"	-	190	4B	10
619244	M 14	72	34.3	21	-	16	271	1E	10
619245	R 1/4"	60	23.5	21	1/2"	-	133	4B	10
619246	R 5/16"	60	23.5	21	1/2"	-	129	4B	10
619247	R 3/8"	69	27.5	21	1/2"	-	188	4B	10
619248	R 7/16"	69	27.5	21	1/2"	-	187	4B	10
619249	R 1/2"	72	34.3	21	-	16	275	1E	10



## 2077/2BI

### Spring clip pliers

- material: special tool steel
- material pivoting tip: special carbon tool steel
- surface finish: chrome plated to standard EN12540
- tips black finish
- heavy duty double - component handles
- jet stamp UNIOR
- for hose clips on cooling, heating, fuel or screen-washer systems

#### Advantages:

- fits most standard sized clamps
- position lock makes it easy to replace hose clamps

#### How to use the tool:

- Spring clip pliers are used for opening the tube clamps, enabling quick and safe removal of tubes from tube prolongations. They are also used for closing the tube clamps when tubes are attached to tube prolongations to prevent tubes from falling off the prolongations and thus ensuring safe movement of fluids. The pliers have been designed in such a way so that only a minimum force is sufficient to create large pressure upon the clamp, ensuring safe and durable connection of the tube to the tube prolongation. The pliers have been shaped in such a way so that they can be efficiently used at places which are difficult to access, thus enabling quick and easy handling. Firm and safe grip is ensured by the ergonomic shape of the handles.

#### Use for:

- Alfa Romeo, Audi, Citroen, Fiat, Ford, Hyundai, Lancia, MAN, Mercedes, Opel/Vauxhall, Peugeot, Porsche, Renault, Seat, Toyota, VW, Volvo, etc.



	L			
619250	235	301	4B	1

# COMBINE, NOT DESTROY

## Why do we need special pliers for clips, joints and clamps?

Without the special pliers, it is often not possible to install clips, couplings and clamps. With an unsuitable tool, one can damage the joint or even destroy it.

In cars, there are many clips, joints and clamps that fasten or join individual car parts. They are of various shapes and have different joining mechanisms, therefore they often cannot be mounted or removed without proper tools. The development of clips and the tools for clips goes hand in hand: new clip shapes emerge that have new functions and with them also new tools.



*There are several types of pliers for clamps, because clamps are very different. Without special pliers, they can not be closed or opened properly. Sometimes mechanics use other tools, but then it is possible to quickly damage and destroy the clamp. If this procedure is nonetheless successful, a quick glance at the clamp can show that the mechanic used an emergency solution.*

The past simple clips that could be squeezed or opened with a screw are almost never used in vehicles anymore. In their place, they started using various clips, at first mainly spring clamps. The use of spring clamps is simple, and fastening and opening them is quick. Spring clamps are used in pipes for cooling systems, in suction and vent pipes, in fuel lines, etc. The clamps have springs that are strong enough to tighten the pipe onto the pipe nozzle and do not permit the pipe from slipping off. The spring force is even calculated so accurately that the clamp does not damage the pipe or the attachment. Because the spring of the clamp is strong, it can be opened only with a special tool - pliers for spring clamps. On each jaw, the pliers have a different attachment that has to be inserted into the ear of the spring clamp. When the pliers are pressed, the spring opens so that the pipe can be removed from the nozzle. Because the springs are relatively strong, other tools might be very difficult to use to open the spring clamps, and it is almost entirely impossible where there is little room for accessing the clamp.

Often there is so little room to access the spring clamps that not even standard pliers for spring clamps can be used. In such cases, the so called automatic pliers for spring clamps have to be used that have a special attachment on the 600mm long bowden in order to reach the spring clamp in the most inaccessible places. With the attachment, it is possible to open spring clamps of various sizes (from 18mm to 54mm). The pliers have a stop with teeth for fastening pliers into a desired position (8 positions) to make it easier to remove the clamp.

With cuffs that guard the homokinetic joints (as well as in some coupling pipes and attachments), special disposable clamps are usually used that are called Oetiker clamps. The clamps have special pins and sockets (there are several sockets so that the clamp adjusts to the cuff size) into which pins are inserted. The pliers squeeze the cuff and deform it so that it can no longer be opened (if we want to remove it it usually has to be cut). Therefore, pliers have special attachments on each jaw and between

them a central (eccentric) attachment that pushes the ear of the clamp towards the inside so that the ear is correctly deformed and that the clamp cannot open anymore. It is important that the pliers for Oetiker clamps are long enough so that we can reach clamps in hard to access places and to achieve greater pressure on the clamp with little force.

Where two plastic parts are connected, plastic pipe and plastic pipe nozzle, special clamps are used that cannot damage plastic nozzles. These are so called click clamps, because a characteristic click can be heard when squeezing the clamp. The clamp namely has a predefined flexibility and cannot be squeezed any further, only until the click sound is heard. Thus, it is not possible to damage the plastic pipe or the plastic nozzle. The click clamps can be taken off or put on freely, but this procedure also requires a special tool - pliers for click clamps.

In gasoline and diesel engines, several types of clamps are used for fuel induction, but due to safety all are made from plastic materials, thus they require special pliers. These clamps must be made from plastic materials so that a spark does not go off when removing them that could ignite the fuel. The pipes for the supply of fuel usually have a diameter of 10 to 12mm. The clamps should be removed with pliers that must not close all the way in order not to crush the clamp or the nozzle. On the jaw, the tool has two hardened plugs that squeeze the clamp so that the pipe can be removed. The pliers jaw has a suitable size and is adjusted so that it enables easy work under high load.

## Pliers for clips and clamps



Spring clamps have a relatively strong spring that can only be opened in an easy way using special pliers.



The pliers have a stop that holds the spring open so that the clamp can be removed easily.



Automatic pliers for spring clamps can be used for clamps that are mounted in the most inaccessible places.

### TOOLS USED:

#### Spring clip pliers - 2077/2BI

- material: special tool steel
- material pivoting tip: special carbon tool steel
- fits most standard sized clamps
- lock mechanism
- surface finish: chrome plated to standard EN12540
- tips black finish
- heavy duty double - component handles

#### Automatic Spring Clip Pliers - 2089/2BI

- material: special tool steel
- for hose clips on cooling, heating, fuel or screen-washer systems
- position lock makes it easy to replace hose clamps
- surface finish: chrome plated to standard EN12540
- heavy duty double - component handles

#### Slothholder pliers for OETIKER® collars - 2078/2BI

- material: special tool steel
- for automotive pressed axlecuffs OETIKER®
- exact deformation of the axlecuff ear
- longer, for easy deformation of axlecuff ears
- for almost all passenger cars
- heavy duty double - component handles

#### CLIC® collar pliers - 2080/2BI

- material: special tool steel
- to remove and reassemble CLIC spring-clips
- surface finish: chrome plated to standard EN12540
- heavy duty double - component handles

#### Quick coupler pliers for fuel pipes - 2079/2BI

- material: special tool steel
- for disconnecting fuel pipes
- spring for reopening
- surface finish: chrome plated to standard EN12540
- tips black finish
- heavy duty double - component handles



To mount cuffs, Oetiker coupling clamps are used that can only be mounted with special pliers.



The pliers deform the ear of the clamp so that it can no longer be opened.



With pliers for clamps for fuel, release the clamp so that the pipe can be removed.



To couple fuel lines, clamps of plastic materials are used; with metal clamps, a spark might go off.



Using pliers, it is possible to open the reusable clamps without damaging them.



When the special click is heard, the clamp is correctly fastened.

## 2078/2BI

### Slothholder pliers for OETIKER® collars

- material: special tool steel
- heavy duty double - component handles
- jet stamp UNIOR
- for automotive pressed axlecuffs OETIKER®

#### Advantages:

- exact deformation of the axlecuff ear
- longer, for easy deformation of axlecuff ears
- for almost all passenger cars

#### How to use the tool:

- Slotholder pliers are used for opening the tube clamps, enabling quick and safe removal of tubes from tube prolongations. They are also used for closing the tube clamps when tubes are attached to tube prolongations to prevent tubes from falling off the prolongations and thus ensuring safe movement of fluids. The pliers have been designed in such a way so that only a minimum force is sufficient to create large pressure upon the clamp, ensuring safe and durable connection of the tube to the tube prolongation. The pliers have been shaped in such a way so that they can be efficiently used at places which are difficult to access, thus enabling quick and easy handling. Firm and safe grip is ensured by the ergonomic shape of the handles.

#### Use for:

- Audi, BMW, Chrysler, Ford, GM, Honda, Mazda, Mercedes, Nissan, Opel/Vauxhall, VW

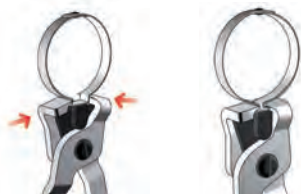

L

619251

230

316

4B

1

## 2079/2BI

### Quick coupler pliers for fuel pipes

- material: special tool steel
- surface finish: chrome plated to standard EN12540
- tips black finish
- heavy duty double - component handles
- jet stamp UNIOR
- for disconnecting fuel pipes

#### Advantages:

- spring for reopening

#### How to use the tool:

- This tool is used for the removal of the quick couplers that connect fuel lines. The tool has two hardened pins in the jaws that compress the couplers during removal or repair (the hose can then be removed). The jaw is dimensioned and adjusted to enable safe and easy work with great force in a limited space.

#### Use for:

- Opel/Vauxhall, Fiat, GM, VW, Renault etc.

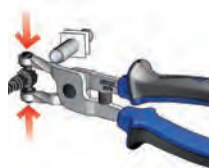

L

619252

206

264

4B

1

## 2080/2BI

### CLIC® collar pliers

- material: special tool steel
- surface finish: chrome plated to standard EN12540
- heavy duty double - component handles
- jet stamp UNIOR

#### Advantages:

- separating and closing with 180° invert of the pliers

#### Usage

- to remove and reassemble CLIC spring-clips
- CLIC collar pliers are used for opening the tube clamps, enabling quick and safe removal of tubes from tube prolongations. They are also used for closing the tube clamps when tubes are attached to tube prolongations to prevent tubes from falling off the prolongations and thus ensuring safe movement of fluids. The pliers have been designed in such a way so that only a minimum force is sufficient to create large pressure upon the clamp, ensuring safe and durable connection of the tube to the tube prolongation. The pliers have been shaped in such a way so that they can be efficiently used at places which are difficult to access, thus enabling quick and easy handling. Firm and safe grip is ensured by the ergonomic shape of the handles.

#### Use for:

- Audi, Citroen, Fiat, Mercedes, Opel/Vauxhall, Peugeot, Renault, VW



L

619253

190

244

4B

1

**2081/3**

**Grip hose clamp pliers for stopping the flow of fluids**

- material: jaws – special carbon steel.
- handles made from sheet metal
- used for the stopping of the flow of oil, gasoline...

**Advantages:**

- jaws are free of sharp edges, so that sensitive hoses do not sustain damage
- plastic moulded T handle enables improved grip for the user
- fast and simple stoppage of the flow of fuel and other liquids
- universal locking mechanism

**How to use the tool:**

• The tool for stopping the flow of fluids is an indispensable tool when changing various automotive parts connected with liquid-bearing hoses. The tool's main function is the stoppage of the flow of various fluids in soft hoses so that a mechanic can replace a certain car part without interruptions or worrying over a potential spillage. The tool can be used on soft hoses in cars, trucks, farming machines as well as various nautical vessels, however, the hose diameter may not exceed 55 mm at any time, as in that case the stoppage of the flow is not guaranteed.



	L					
619254	285	55	611	TE	1	

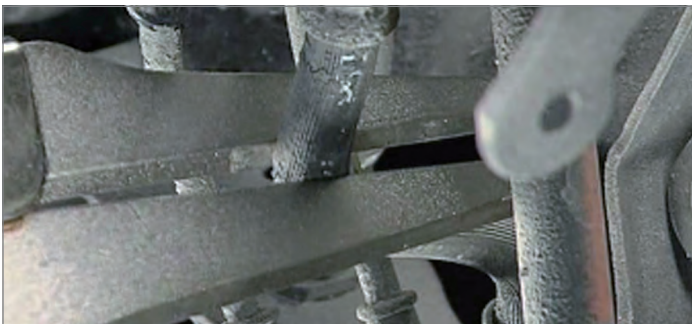

**2082.1**

**Spare chain for item 2082/3**

- material cutters: alloy steel



	L					
619256	305	184		TE	1	

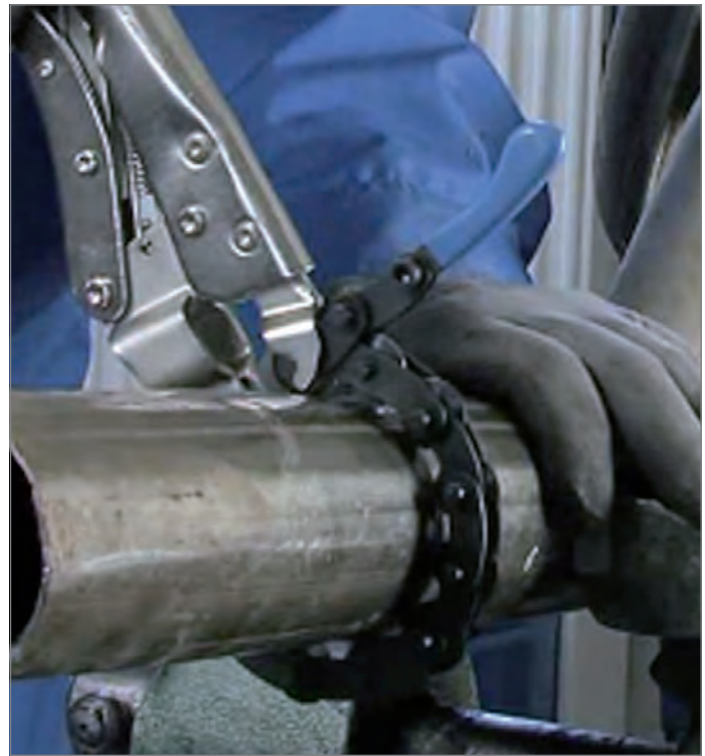

**2082/3**

**Grip pliers for cutting exhaust pipes**

- material: jaws – special carbon steel
- handles made from sheet metal
- cutting capacity: 25–85 mm
- used for cutting exhaust pipes in partial replacements of exhaust systems

**Advantages:**

- the plastic-coated T-handle provides better grip for the user
- universal locking mechanism
- very long cutting chain

**How to use the tool:**

• This tool is primarily intended for cutting exhaust pipes but, due to the design of its cutting chain and blades, it can also be used for copper pipe, plastic pipe and various other pipes with diameters between 25 and 85 mm. The tool is safe and easy to use due to accessories such as: – a longer cutting chain enabling you to cut pipes with diameters of up to 85 mm; – larger cutting blades, enabling you to cut steel tube up to 3 mm thick, brass tube up to 4 mm thick, PVC tube up to 5 mm thick; – a plastic-coated T-handle that decreases the amount of force necessary to use the tool, enhances grip and prevents slipping; – a universal locking mechanism that keeps the tool in position until you release the locking mechanism and stop cutting. The cutting chain is subject to wear, which is why we are offering it as a spare part (art. 2082.1).

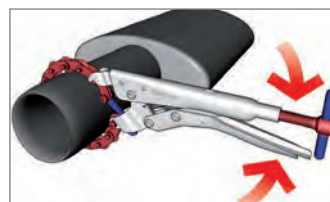
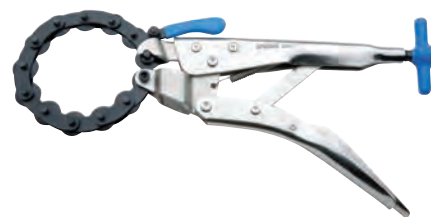

	L					
619255	330	25	85	765	TG	1



2084

**Professional auto inspection set**

- with long life LED light
- available in durable plastic bag
- the magnet's lifting capacity: 3.5 kg
- included in the set: 1 round mirror O60, 1 angular mirror (65 x 42 mm), 2 bits attachments, 3 L1154F batteries, 1 bag with the SOS tool tray
- in addition to the LED light, this set includes additional mirrors to facilitate viewing of difficult-to-reach areas inside the car, making this a very useful set. The tools are also intended for lifting small metal objects such as screws, nuts, etc. The set comes in an attractive and durable bag. Individual tools have been placed in the SOS tool tray to make them easier to find.



	A	B	H	L1				
619742	240	110	45	650	3.5	360	1E	1

2086

**Magnetic tray**

- Material: stainless steel, corrosion resistant
- keeps parts and tools right where you need them
- holds any small nuts, bolts and steel parts

**Advantages:**

- powerful permanent magnet cover with protective rubber foot
- can be used in any position

**How to use the tool:**

- With its powerful rubber-protected magnet, this magnetic tray is suitable for practically all industrial applications ranging from car repair shops to everywhere where it can be attached to a metal surface. It can be used in all positions - the magnet is so powerful that the tray can even be fitted upside-down. The tray is intended for protecting screws, nuts and the like against being misplaced, and for storing them in a central location to minimise the time needed to find a specific item.
- for usage in garage, engine, household work



		D	H					
619728	150	40	3	387	1F			1

2083

**Telescopic magnetic pick-up tool with light**

- for lifting nuts, bolts, screws
- Advantages:**
- batteries protected against humidity
  - included in the set: 3 LR41 batteries
  - with light, for dark places between the machine parts

**How to use the tool:**

- This tool is intended for picking up small metal objects. It has a special light that activates automatically upon being extended from its housing. It is useful for partly unlit spaces such as the inside of engines. When no longer needed, simply fold back the tool and the light will immediately deactivate. The tool has a fastener.



	L	L1						
619741	170	660	0.5	55	1F			1



2087

**Flexible pick up tool with magnet**

- The flexible magnetic pickup is designed to collect metal objects from hard to reach spots.

**Advantages:**

- It features a flexible stem with a strongly magnetic tip.
- The magnet is capable of lifting metal objects of up to 1 kg.
- The tool is fitted with an ergonomically designed handle, ensuring easy and efficient operation.



		L	D					
619929	1	500	15	127	4B			1



2085

**Claw pick-up tool**

**Advantages:**

- This adjustable tool is easy to navigate through difficult-to-reach areas. To enable quick and reliable gripping of objects, it has three claws that extend or return to their original position upon pressing or releasing the button, respectively.

**How to use the tool:**

- for lifting small specially non-metallic parts like bolts, nuts, screws



	L							
619883	510	15	150	4A				1

# 2091



With 26 LED lamps (21 in front and 5 on top).

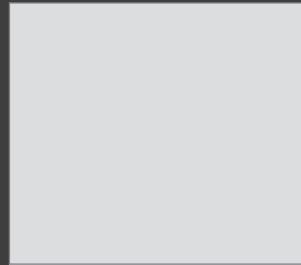

21 LED can be switch on between 4 and 5 hours, 5 LED on top 13 hours



With three magnets.



Simple light angle adjustment from 0 to 180°.

## 2091

### LED light

#### Advantages:

- with 26 LED lamps (21 in front and 5 on top)
- 21 LED can be switch on between 4 and 5 hours, 5 LED on top 13 hours
- with two adjustable hangers
- with three magnets
- simple light angle adjustment from 0 to 180°
- made from user friendly plastic material
- with two adapters (12/24V in 100-240 V)
- magnet in bottom carries complete weight of LED light
- Li-Ion battery



	L	A			
620237	250	55	512	1G	1

## 1976/2

### Adjustable oil-filter wrench

- material gripping arms: carbon tool steel
- for assembling or disassembling oil filters
- removes all type of oil filters from 60 to 120 mm diameter

#### Advantages:

- arms are ribbed, for better gripping oil filters

#### How to use the tool:

As car repair shops usually need to replace various types of oil filters, we have developed a tool that can be used on the majority of standard ones. When used, the tool conforms to the filter as tightening it makes it grip the filter. The tool can be used on all filters with diameters ranging from 60 to 120 mm. Because of the limited space during changing, the tool is sized and adjusted to require as little space as possible. The hooks are ribbed to make them suitable for filters without an edge to allow gripping and which would be difficult to replace with conventional methods. The tool works in both directions and thus allows both the tightening and loosening of oil filters, as it adjusts and utilises the effort invested optimally in both cases.

#### Important!

- used with ratchet 3/8" and proper extension bar



			H			
619257	60	120	3/8"	60	635	1G 1

## 1978/2

### Wrench for reservoir

- material arms: carbon tool steel
- for removing plastic fuel tank nut
- for assembling or disassembling

#### Advantages:

- quick gripping of fuel tank nut

#### How to use the tool:

This tool has three removable hooks that grip the fuel tank cap firmly so it does not move. As access to this cap is usually difficult when making replacements, the tool is constructed so that it requires minimum space. Simply place the tool on the cap and rotate in the appropriate direction. The tool adapts to the cap itself and the cap can then be removed very quickly. The replacement of the cap is also straightforward. This tool ensures safe work and a long service life.

#### Important!

- use with socket or wrench dimension 22



				H		
619266	120	155	22	73	670	1G 1

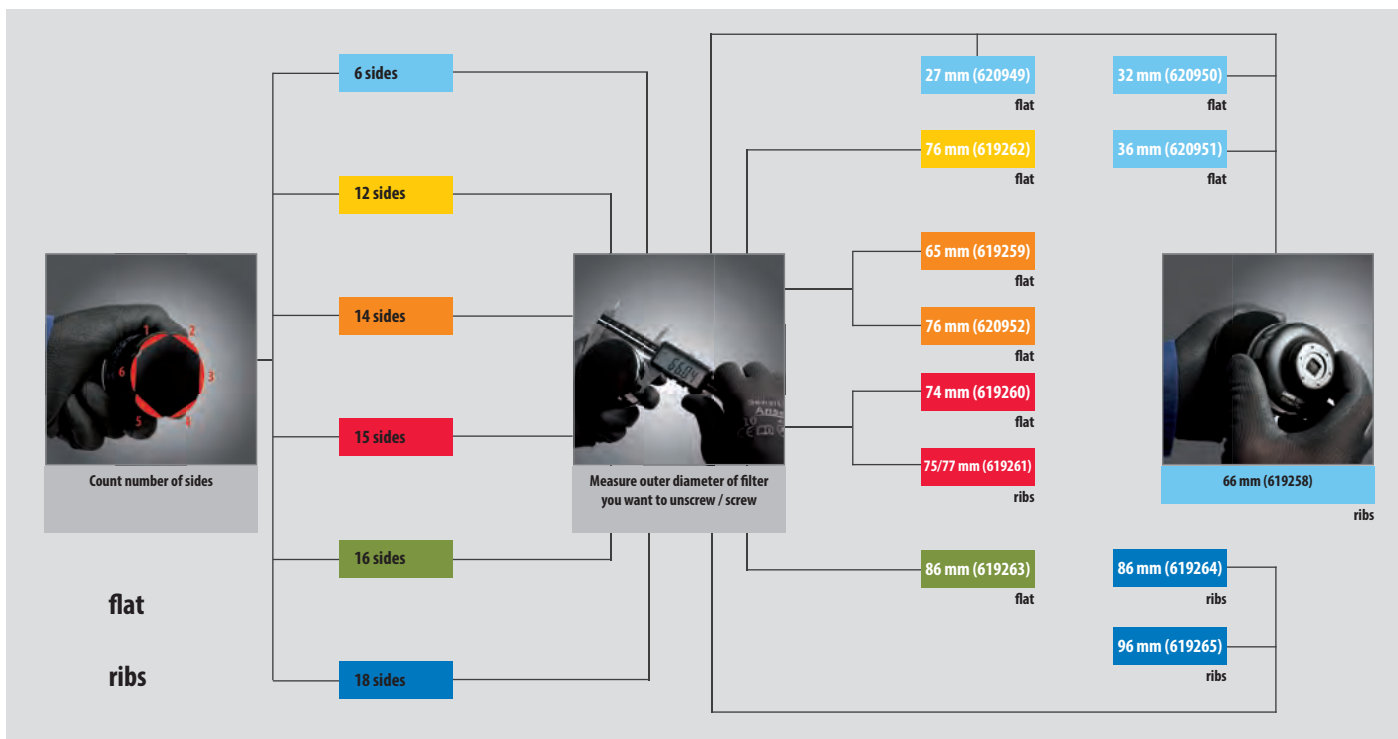

## 1977/6

### Oil-filter wrench

- material: special tool steel
- lacquered
- for assembling or disassembling oil filters
- for oil filters in restricted access area
- used with ratchet 3/8" and proper extension bar

#### How to use the tool:

- This tool comes in as many as 12 sizes, which can be used on the majority of standard car and motorbike oil filters on the market. Using it is simple as all that is needed is to place the appropriate tool on the filter and rotate it with ease. The tool can also be used when fitting oil filters as the design and material have been carefully selected so that the tool can withstand the maximum force applied to it. Because of the surface protection, the tool is highly resistant to scratches and damage as well as to atmospheric and chemical effects.



	D	360°/n	D1	H		
620949	27	6	37.5	33.5	68	1E 1
620950	32	6	43.5	34.6	81	1E 1
620951	36	6	48.4	34.9	89	1E 1
619258	66	6	73	37	124	1E 1
619259	65	14	70.7	36.8	129	1E 1
619260	74	15	81	36	146	1E 1
619261	75 - 77	15	81.4	41.8	165	1E 1
619262	76	12	82	35	137	1E 1
620952	76	14	81.3	37	160	1E 1
619263	86	16	96	47.2	201	1E 1
619264	86	18	92	39.5	171	1E 1
619265	96	18	102	36.8	190	1E 1

## 1977PB12

### Set of oil-filter wrenches in plastic box



622702	12	2300	15	1
1977/6 (27 x 6, 32 x 6, 36 x 6, 66 x 6, 65 x 14, 74 x 15, 75 - 77 x 15, 76 x 12, 76 x 14, 86 x 16, 86 x 18, 96 x 18)				



**2089/2BI**

**Automatic Spring Clip Pliers**

- material: special tool steel
- material pivoting tip: special carbon tool steel
- surface finish: chrome plated to standard EN12540
- heavy duty double - component handles
- for hose clips on cooling, heating, fuel or screen-washer systems

**Advantages:**

- fits most standard size clamps
- position lock makes it easy to replace hose clamps

**How to use the tool:**

• The pliers are used for opening tube spring clips used on cooling and heating systems which enables quick and safe removal of tubes from tube extensions. Suitable for spring clips with a grip ranging from 18 to 54 mm. The 600 mm long Bowden cable enables efficient use in hard to reach places where clips cannot be reached with other pliers. The pliers include a toothed blocker with 8 positions for opening clips or fastening them in a custom position which makes the removal of clips easier and with no additional force necessary. The handles are designed so that when the pliers' jaws are open the widest they are easy to squeeze with as little force as possible.

**Use for:**

- Alfa Romeo, Audi, Citroen, Fiat, Ford, Hyundai, Lancia, MAN, Mercedes, Opel/Vauxhall, Peugeot, Porsche, Renault, Seat, Toyota, VW, Volvo, etc.



	L	L1		
<b>620234</b>	230	600	415	<b>1G</b> 1



**175/2**

**Wrench for oil drain plugs**

- material: chrome vanadium
- entirely hardened and tempered
- surface finish: chrome plated according to EN12540



	L1	L2	D	
<b>605112</b>	8 x 10	203	169	10 305 <b>4A</b> 10



**205/2**

**Strap wrench**

- material: chrome vanadium
- strap from rubberized cloth
- drop forged, entirely hardened and tempered
- surface finish: chrome plated according to EN12540



	L			
<b>601024</b>	220	60	140	225 <b>1E</b> 10

**205.1**

**Strap for 205/2**

- strap from rubberized cloth



<b>602841</b>	62	<b>1E</b>	10
---------------	----	-----------	----

**206/2**

**Chain wrench**

- material: chrome vanadium
- drop forged, entirely hardened and tempered
- surface finish: chrome plated according to EN12540



	L			
<b>601025</b>	220	60	140	330 <b>1E</b> 10

**206.1**

**Chain for 206/2**



	L			
<b>620938</b>	500	150	<b>1E</b>	5

**1980**

**Optical tester in plastic box**

- for measuring the concentration of electrolytes in the battery in the range from 1,10 to 1,40 Kg/L
- for measuring the usefulness of coolant (ethylene or propylene) in the range till -50°C
- for measuring the usefulness of windscreen fluid in the range till -40°C
- scale grating 0,01 Kg / L in measuring the electrolyte concentration and 5 °C in the measurement of the other two fluids
- packed in a plastic box and SOS tool tray, which allows safe storage of tester
- supplied with pipette and screwdriver to adjust the calibration
- included instructions for use

**Important!**

- before and after the use the tester needs to be cleaned



<b>621403</b>	315	<b>1G</b>	1
---------------	-----	-----------	---

**1910****Curved dolly**

- material: special tool steel
- head polished: mirror polished



A1 A2 B H

619206 80 74 58 70 1573 **TE** 1**1911****Anvil dolly**

- material: special tool steel
- head polished: mirror polished



A B H

619207 102 72 62 1444 **TE** 1**1912****Round peen end dolly**

- material: special tool steel
- head polished: mirror polished



D B H

619208 54 44 425 759 **TE** 1**1913****Light dinging spoon**

- material: special tool steel
- head polished: mirror polished



L A B H

619209 250 110 48 51.5 382 **TE** 1**1914****Double end round dolly**

- material: special tool steel
- head polished: mirror polished



D1 D2 H

619210 56 56 58 756 **TE** 1**1915****Large end dolly**

- material: special tool steel
- head polished: mirror polished



A1 B1 A2 B2 H

619211 90 70 39.9 38.2 125 1434 **TE** 1**1916****Flat spoon**

- material: special tool steel
- head polished: mirror polished



L B C H

619212 250 29.5 4 99 589 **TE** 1**1917****Double blade spoon**

- material: special tool steel
- head polished: mirror polished



A B H

619213 171 58.5 401 1747 **TE** 1**1918****Double blade spoon**

- material: special tool steel
- head polished: mirror polished



A B H

619214 179 59 510 2408 **TE** 1**1919****Flat spoon**

- material: special tool steel
- head polished: mirror polished



L B H

619215 266 51 68.5 839 **TE** 1**1920****Angle dolly**

- material: special tool steel
- head polished: mirror polished



A B H

619216 109 59 17 634 **TE** 1

1921

Thin doe dolly

- material: special tool steel
- head polished: mirror polished



619217	A	B	H				1
118	55	24	950	TE			1

1925

Curved dolly

- material: special tool steel
- head polished: mirror polished

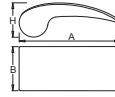

619221	A	B	H				1
133	58.5	45	1175	TE			1

1929

Drip moulding spoon

- material: special tool steel
- head polished: mirror polished

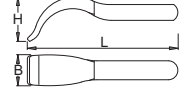

619225	L	B	H				1
236	49	70	1223	TE			1

1922

Grid dolly

- material: special tool steel
- head polished: mirror polished



619218	A	B	H				1
122	59.5	30	1378	TE			1

1926

Heel dolly

- material: special tool steel
- head polished: mirror polished

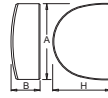

619222	A	B	H				1
79	30	61	899	TE			1

1930

Reverse curve hammer

- material: special tool steel
- head polished: mirror polished
- handle: octagonal shape, hickory wood

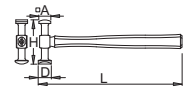

619228	L	A	D	H			6
325	27	29.6	106	395	TC		6

1923

Double end hand dolly

- material: special tool steel
- head polished: mirror polished

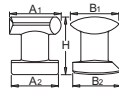

619219	A1	A2	B2	H			1
86	61	61.5	74.5	1162	TE		1

1927

Toe dolly

- material: special tool steel
- head polished: mirror polished

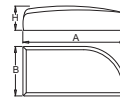

619223	A	B	H				1
121	58.5	29	1329	TE			1

1931

Curved pein & finishing hammer

- material: special tool steel
- head polished: mirror polished
- handle: octagonal shape, hickory wood
- striking face: round 40mm

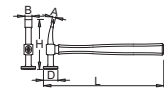

619229	L	A	B	D	H		6
325	8	19.6	40	140	445	TC	6

1924

Utility dolly

- material: special tool steel
- head polished: mirror polished

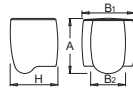

619220	A	B1	B2	H			1
76	73	48	66	1230	TE		1

1928

Shrinking dolly

- material: special tool steel
- head polished: mirror polished

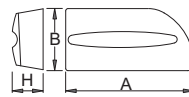

619224	A	B	H				1
122	59.5	25.5	1289	TE			1



1932

Standard bumping hammer

- material: special tool steel
- head polished: mirror polished
- handle: octagonal shape, hickory wood
- striking face round: 40mm, square: 38mm

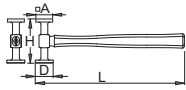

619230 325 38 40 100 445 **TC** 6

1935

Fender & Panel dinging hammer

- material: special tool steel
- head polished: mirror polished
- handle: octagonal shape, hickory wood
- striking face: round 40mm and 32mm

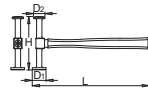

619233 326 40 32 155 475 **TC** 6

1936

Shrinking hammer

- material: special tool steel
- head polished: mirror polished
- handle: octagonal shape, hickory wood
- striking face round: 40mm, square: 38mm
- serrated square striking face

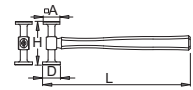

619234 325 38x38 40 100 465 **TC** 10

1933

Straight pein & finishing hammer

- material: special tool steel
- head polished: mirror polished
- handle: octagonal shape, hickory wood
- striking face: round 40mm

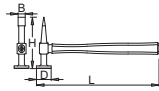

619231 325 8 19.6 40 140 420 **TC** 6

1900

Auto body repair tool set



619226 6 7200 **TF** 1

1923 (86), 1925 (133), 1927 (121), 1929 (236),  
1934 (325), 1936 (325)

1901

Auto body repair tool set



619227 7 7270 **TF** 1

1932 (325), 1934 (325), 1936 (325), 1924 (76),  
1925 (133), 1926 (79), 1927 (121)

1934

Pick & finishing hammer

- material: special tool steel
- head polished: mirror polished
- handle: octagonal shape, hickory wood
- striking face: round 40mm

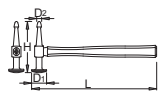

619232 325 40 12 138 406 **TC** 6



### 1940/2BI

#### Trim pin remover

- material: special tool steel
- ergonomic heavy duty double component handle
- for removing trim pin till 8mm
- This tool is used for extracting fastening pins, removing trim and on various upholstery.

#### Advantages:

- tip angled ground
- It's ergonomic design allows easy and safe working in various positions and in difficult to reach places without damage to the items being extracted or removed.

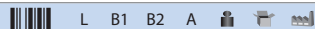
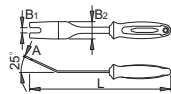

619267 230 8.5 28 2.5 130 4B 1

### 1940.1/2BI

#### Trim pin remover

- material: special tool steel
- ergonomic heavy duty double component handle
- for removing trim pin from 2mm till 15mm
- This tool is used for extracting fastening pins, removing trim and on various upholstery.

#### Advantages:

- tip angled ground
- It's ergonomic design allows easy and safe working in various positions and in difficult to reach places without damage to the items being extracted or removed.

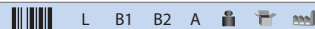
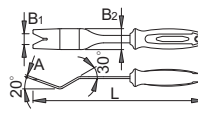

619268 230 16.3 28 2.5 135 4B 1

### 1940.2/2BI

#### Trim pin remover

- material: special tool steel
- ergonomic heavy duty double component handle
- for removing trim pin till 4,5mm
- This tool is used for extracting fastening pins, removing trim and on various upholstery.

#### Advantages:

- tip angled ground
- It's ergonomic design allows easy and safe working in various positions and in difficult to reach places without damage to the items being extracted or removed.

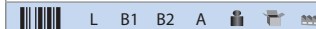
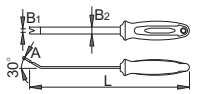

619269 230 5 10 2.5 109 4B 1

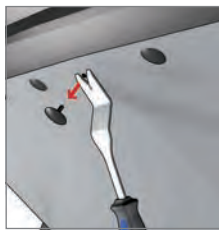

### 1941/2

#### Front windscreen wiper arm remover

- material housing and spindle: carbon tool steel
- for removing front windscreen wiper arms
- for almost all types of cars

#### Advantages:

- protects plastic on housing of wiper arms

#### How to use the tool:

- This tool for the removal of the front windscreen wiper arms has a robust construction and enables the application of greater forces when removing front windscreen wiper arms that have become "glued" to the drive shaft as well as extending the service life of the tool. They are used for removing wipers that are elevated above the surface of the car body. Working with this tool is straightforward and quick.
- use with wrench dimension 17

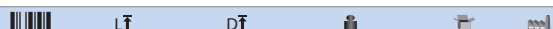
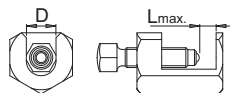
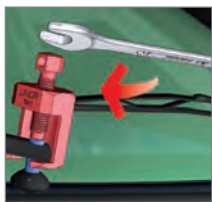

619270 32 18 252 TG 1

### 1942/2

#### Rear windscreen wiper arm remover

- material jaws: chrome vanadium
- for removing rear windscreen wiper arms
- supplied with rod

#### Advantages:

- special adaptor, for protecting wiper arm hose

#### How to use the tool:

- This tool for the removal of rear windscreen wipers is designed to enable the simple removal of all types of rear wipers. The adapter on the remover spindle is protected during work by the hose that supplies the cleaner fluid. The rod included in the set makes it possible to turn the spindle faster and, if greater removal force is required, to use a 13 mm wrench. The construction of the tool ensures its long service life.
- use with wrench dimension 13

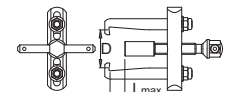

619271 103 22 - 25 288 TG 1

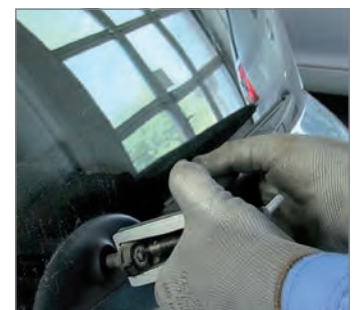



## 1943/2BI

### Windscreen removal set

- material: special tool steel
- for removing front and rear windscreen

#### Advantages:

- extra long nose of the lever, for better accessibility when removing windscreens

#### How to use the tool:

- A set of tools for the removal of glued windscreen glass with the aid of a wire. Using the longer tool, make an opening between the car body and the glass, through which you run the wire that is then attached to both tools. Using the »T« shaped tool, pull the wire between the car body and the glass, thus separating them. The tool is made to allow fast and safe work, while its shape ensures that the work is performed without expending excessive energy.

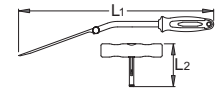

	L1	L2			
619272	354	78	330	TG	1

## 1943.3/2

### Longer tool with BI handle for 1943/2BI

- material: special tool steel
- for removing front and rear windscreen

#### Advantages:

- extra long nose of the lever, for better accessibility when removing windscreens

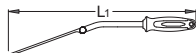

	L1			
621406	354	195	4B	1

## 1943.2/2

### Short tool with handle for 1943/2BI

- material: special tool steel
- for removing front and rear windscreen



	L2			
621405	78	95	1E	1

## 1943.1SQ

### Square steel wire for windscreen removal set



	L (m)			
619611	22	101	1E	1

## 1943.1R

### Round steel wire for windscreen removal set



	L (m)			
619612	22	98	1E	1

## 1944/6

### Double suction lifter

- durable plastic body
- for the transport and positioning of windcreens during fitting and removing operations

#### Advantages:

- loading capacity: 75kg
- two strong suction pads for maximum safety
- suction pads can be set to suit flat and curved surfaces

#### How to use the tool:

- This lifter is useful when replacing and carrying windcreens (they have to be removed to be replaced). The lifter is operated by placing the two suction pads on the windscreen and creating vacuum in them by using the handles. The suction pads then securely grip the windscreen that is to be removed or installed.
- 1. Position it on the windscreen.
- 2. Move the handles to create vacuum between the lifter and the windscreen.
- 3. The windscreen can be safely removed or installed using the lifter.



619740	925	1E	1

## 1945

### Multi-function scraper with blade guard

- plastic material
- blade from high alloy steel
- with blade guard
- This tool is designed for scraping off dirt stuck to various surfaces. Due to its large working surface, the tool scrapes uniformly across the entire surface. It is suitable for removing silicon putty from motor heads, baked-on seals, vignette, etc.

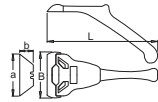

Barcode	L	B	a x b	Weight	Category	Quantity
620240	165	70	60.8 x 18.9	37	1E	1

## 1946

### File holder

- delivered without file, which is available as spare part (article 1946.1)

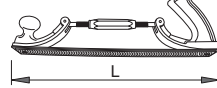

Barcode	L	Weight	Category	Quantity
621477	350	770	1E	1

## 1946.1

### Spare blade for 1946



Barcode	L	B	Weight	Category	Quantity
621478	350	35	274	1E	1

## 2026.1/4

### Spindle for 2026/2

- material: special tool steel
- surface finish: blacken

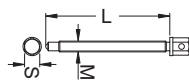

Barcode	Length	Thread	M	L	S	Weight	Category	Quantity
623948	5 - 60	Tr 14 x 2	173	17	240	1V	1	
623949	12 - 75	Tr 16 x 2	177	19	312	1V	1	
623950	22 - 115	Tr 20 x 2	294	22	770	1V	1	

## 1945.1

### Set of 5 blades for 1945



Barcode	Weight	Category	Quantity
621042	33	1E	1

## 2026/2

### Separator puller

- The separator is made of high quality steel.
- Surface finish of screws: burnished, other parts are chrome-plated
- The separator puller is a tool designed to efficiently dismount various machine parts attached to shafts.
- It is indispensable for tasks requiring the safe and deformation-free dismounting of firmly fixed machine parts.
- Our product range includes three sizes of pullers used for taking off objects from shafts. They range from Ø5mm to Ø115mm.

#### Advantages:

- The separator puller consists of a yoke, a spindle, two arms and a gripper assembly, which together allow uniform dismounting.
- The separator puller is designed to allow easy and safe operation

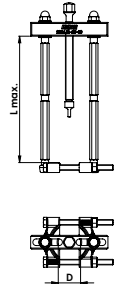

Barcode	D	L	Weight	Category	Quantity
619273	5 - 60	229	2160	1G	1
619274	12 - 75	234	2930	1G	1
619275	22 - 115	325	7180	1G	1

## 2026.3/2

### Pulling cup for 2026/2



Barcode	Length	Weight	Category	Quantity
623951	5 - 60	505	1V	1
623952	12 - 75	971	1V	1
623953	22 - 115	2405	1V	1

# PULLER BEAM AND SPINDLE

## Can machine parts be dismantled in any way other than by using a special tool?

In urgent cases, they can be dismantled by using a convenient tool, however, this may deform or damage the machine parts or the tool itself may be damaged. With

the separator puller, the task may be performed quickly and more importantly, safely.

The machine parts attached to the shaft must be dismantled if you want to replace or repair a certain assembly. The dismantling of two machine parts can be a difficult task. For such tasks, which are common in car repair shops, it is highly recommended to use a special tool called the separator puller.

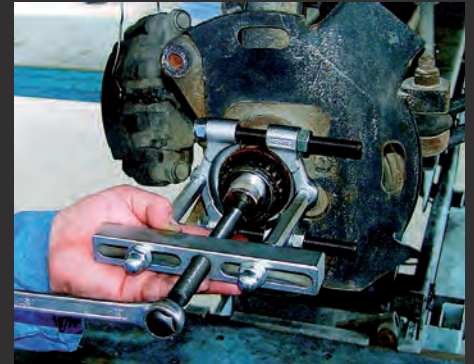

*With a special tool, the separator puller, you can safely dismantle two machine parts without damaging them.*

Joints between two machine parts are often very strong. The joint may be damaged by corrosion, both parts may have been "burned" together, mechanical failure or wear may have occurred, one part may cut into the other, a notch may be deformed, etc. To dismantle such machine parts, it is best to use a special tool, which must be sufficiently robust and made of quality material, since great force may often need to be applied for dismantling. The tool must also be of suitable construction to allow the dismantling of machine parts of various sizes.

Two separate machine parts are dismantled with a separator puller. First, you should install a gripper assembly on the machine part that you want to dismantle. It is composed of two parts, joined by two screws. The screws are used for fitting the gripper assembly on the machine part. Screw an arm on each gripper assembly and install a yoke on the arm. Attach the arms, which can also be extended, to the yoke with the enclosed nuts. Screw the used spindle on the yoke. Rotate the spindle until it reaches the shaft from which the machine part is being dismantled. Rotate the spindle with a suitable wrench until the part is dismantled from the shaft. Occasionally, quite a lot of force must be applied to loosen the joint.

When using the separator puller, you will not damage the shaft or dismantled machine part and, in particular, the mechanic will not injure himself/herself.

## TOOLS USED:

### Separator puller - 2026/2

- The separator puller is a tool designed to efficiently dismantle various machine parts attached to shafts.
- The separator puller consists of a yoke, a spindle, two arms and a gripper assembly, which together allow uniform dismantling.
- Our product range includes three sizes of pullers used for taking off objects from shafts. They range from Ø5mm to Ø115mm.
- The separator is made of high quality steel.
- Surface finish of screws: burnished, other parts are chrome-plated

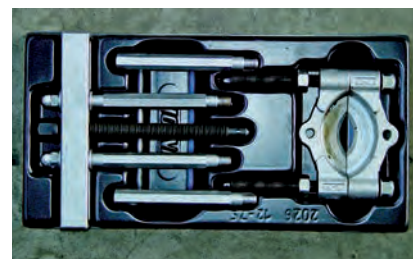

*If you turn the gripper assembly of the separator puller, you get a flat bearing surface.*



*First, take the gripper assembly from the tool.*



*Adjust the gripper assembly to the size of the part being dismantled.*



*Join both parts of the gripper assembly with screws.*



*Install two arms on the gripper assembly.*



*Attach a yoke on the arms with nuts. Install the yoke with a spindle on the arms. Be careful to properly install the washers into the yoke.*



*Screw the spindle with a suitable wrench until the joint between the two machine parts is loosened.*

2038

Inner bearing race puller

- It is used to easily, quickly and cleanly remove inner bearings from the wheel hub. The tool is designed to remove the inner bearing race without the risk of any damage and without needing any additional tools such as files, hammers or cutters. The tool has 4 track bushes that are used to remove bearing races with diameters from Ø40 to Ø60 mm. The track bush clasps the bearing race firmly and thus prevents any kind of slippage. The tool can be used for: Audi, BMW, Ford, Mercedes-Benz, Peugeot, Renault, Toyota, VW, etc.
- With 4 jaws; dimension 1 - from Ø40 to Ø45, dimension 2 - from Ø45 to Ø50, dimension 3 - from Ø50 to Ø55, dimension 4 - from Ø55 to Ø60



620228	3585	TG	1

2032/2

Ball joint puller

- material: special tool steel
- jaw capacity: 23mm
- maximal height: 53mm
- for extracting ball joints from steering wheel and suspensions

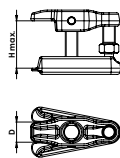

	D	H <sub>T</sub>			
619736	23	53	780	TG	1

2038.1/4

Spindle for 2038

- material: special tool steel
- surface finish: blacken



		M	L	S			
623954	40 - 60	Tr 16 x 2	177	19	320	1V	1

2038.2/4

Pulling jaw for 2038



623955	40 - 45	390	1V	1
623956	45 - 50	365	1V	1
623957	50 - 55	345	1V	1
623958	55 - 60	365	1V	1

2041/2

Homokinetic joint puller



How to use the tool:

- The puller is used to dismount or repair homokinetic joints of various sizes. Before dismantling the joint, check whether the homokinetic joint can be dismantled. First, remove the top adjustable holder and then insert the joint through the ring and by mounting the top adjustable holder clamp the joint into the puller. The homokinetic joint includes a nut which can be used to screw in or dismount the joint. Before screwing in the nut, remove the circlip that is holding the upper and lower part of the joint. By simultaneously pressing two buttons, the holder can be adjusted to the suitable length of the joint. Advantages: the tool can be used on cars, it does not damage the joint, it saves time when dismantling the joint etc.

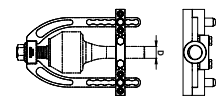

	D			
620232	18 - 36	2130	TG	1

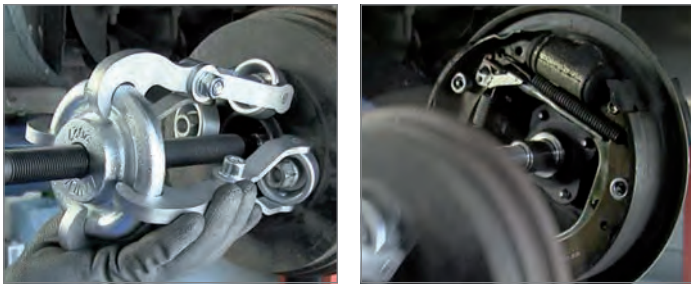

### 2028/2P

#### Wheel balancing pliers

- material: chrome vanadium
- surface finish: chrome plated to standard EN12540
- handles plastic dipped



	L			
619288	250	406	48	1

### 2029/2

#### Socket 1/2" for removing brake drums

- material: chrome molybdenum
- screw special carbon tool steel
- for removing brake drum
- two pieces in set



#### How to use the tool:

- Since a car's brake drums are often difficult to remove, special tools are required for this task.
- The tool consists of two slip-on bolts, which are first screwed into the brake drum in a symmetrical arrangement.
- By uniformly screwing the bolts in using a ratchet or a wrench, the brake drum is gradually removed.
- Upon removing the brake drum, simply detach and stow the tool.



		L	D	L1			
619148	M 8	64	22.9	28	167	1E	1

### 686/2

#### Professional ball joint puller

- material: special tool steel
- drop forged, entirely hardened and tempered
- surface finish: chrome plated according to EN12540, screw blackened
- for cars

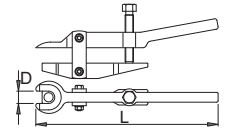

	D	L			
601772	16	260	925	1H	1



### 2027/2

#### Hub and wheel drum puller



- material hook cups: chrome molybdenum
- with five extractor hooks
- for extracting wheel hubs, up to a hole diameter of 250 mm
- This tool is intended for the disassembly of various wheel hubs. It is designed for simple and flexible use. With the extractor hooks supplied, the hubs can be removed with three, four or even five hooks, depending on the type of hub. Because its use is extremely flexible due to the five extractor hooks, the tool is useful for the majority of hub types up to a diameter of 250 mm. The tool consists of a spindle, five extractor hooks and forged hook handle. The handle also has an additional notch that prevents the extractor hooks from sliding off the tool during the assembly or disassembly of the hub. The strong construction allows safe and long-term use with high loads. We recommend that you do not use pneumatic hammers!

#### How to use the tool:

1. Assemble tool, mount only number of extractor hooks needed
2. Mount extractor hooks to wheel drum
3. Turn spindle to start pulling wheel drum

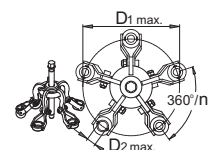
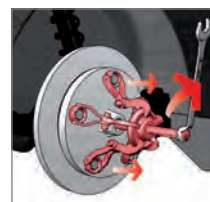
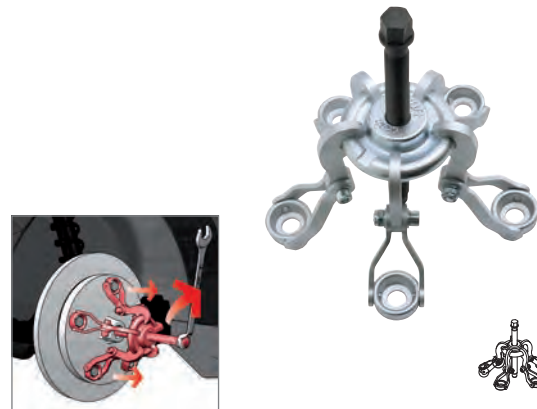

	D1	D2		n			
619278	250	18.5	24	3 - 5	4640	1G	1

# REMOVAL OF THE DRUM AND HUB

**There are several tools available for repairing drum brakes. But do we really need all those tools for this task?**

The wheel hub cannot be extracted securely and free of damage without a special tool. Various attempts to extract the hub with a tire lever or any other useful accessory often end poorly.

The extraction of the wheel drums and hubs is a special task in car service workshops. It must be performed with a special tool and by an experienced mechanic. Brake hubs are installed especially on older vehicles for braking of the rear wheels, and with these vehicles, the brake drums and the brake mechanism must be properly cleaned, while the brake shoes and brake pads must be checked every year, since drum brakes are more sensitive to external factors than disc brakes due to their structure.



*Brake shoes are equipped with strong springs that need to be removed if you want to extract the brake shoes. There is usually little space for accessing the spring. The spring reaches the pointed hook of the special pliers, while the other hook has an adjustable extension that is positioned against the brake shoe so that the pliers can stretch and remove the spring.*

It is clear that the wheel must be removed first in this procedure. Once the wheel is removed, the brake drum and the wheel hub are exposed. The hub can have three, four or five bolt attachments to which the wheel is affixed with lug nuts. The extraction of the brake drum is usually not a difficult task, however it can cause some problems particularly due to corrosion. A considerable amount of rust can quickly accumulate on the brake drum, making it difficult to separate the drum from the hub. In this case, a special steel brush must be used. It should be very narrow to allow the mechanic to reach all parts. There is always little space between the bolts and the hub, so this is where the majority of rust and dirt collects. These can be removed only with a specially designed brush.

This brush is also used for cleaning disk brakes. Disk brakes are installed in vehicles for the braking of the front wheels. When disk brakes perform braking, residue accumulates in the disc housing (similar to the brake drum) due to the wear of the disc and brake pads. This "waste" material needs to be removed during the replacement of the brake pads.

Once the drum and the external part of the hub are properly cleaned, you can start with the disassembly of the brake drum. To allow the disassembly, brake drums are equipped with two threads for bolts. The slip-on bolts must be screwed into the brake drum. Usually, a wrench (or a ratchet) must be used for screwing from the beginning. By using the wrench, both slip-on bolts must be screwed equally (symmetrically). Slip-on bolts push away the brake drum for its extraction. Once the drum is extracted, we can start repairing the brake mechanism, clean the interior of the brake drum and shoe, replace the brake pads, adjust the handbrake etc.

For the disassembly of the brake shoes, again a special tool is needed. Brake shoes are equipped with springs that need to be removed if you want to extract the brake shoes. Different mechanics use various useful tools, but they do not achieve a good result. There is little space around the brake shoe spring (especially on some models), and if you want to grab and squeeze the spring properly, special brake spring pliers must be

used. The pliers are fitted with a special adjustable extension that can be installed on the brake shoe. This adjustable extension has a grooved face to prevent slipping when the pliers are squeezed to stretch the spring.

There is even less space at the point of attachment of the handbrake steel wire. Therefore, the wire is not easily extracted. Here, you can use the handbrake wire pliers that allow you to quickly stretch and mount or remove the handbrake wire.

The extraction of the wheel hub is a special task. The hub must be extracted to perform various repairs. This task should be performed only with the appropriate tools, otherwise you may still manage to extract the hub, but you will most likely damage the hub or the brake drum with certain tools (the brake drum may burst during a non-professional extraction of the drum, not to mention a non-professional extraction of the wheel hub). As early as a few decades ago, when hub and wheel drum pullers were not available on the market, many car mechanics produced their own tools to extract the hub without causing defects.

The Unior hub and wheel drum puller has a special structure. It consists of a strong forged handle with a double function. It must be equipped with extractor hooks with special hook cups. The number of hooks (three, four or five) depends on the structure of the hub, which determines also the manner of mounting (with bolts or nuts). The extractor hooks are then mounted on the bolts (on which the wheel is screwed). The nuts are screwed on the bolts so that the extractor hooks are "seated" properly on the brake drum. Once the hooks are mounted, tighten the spindle, which reaches the centre of the hub. The spindle is additionally tightened with a suitable wrench until the hub and the brake drum are extracted. This task strongly burdens the tool, therefore it is relatively robust. However, it should be handled gently, therefore the use of pneumatic hammers for tightening the spindle is not recommended.

## TOOLS USED:

### Hub and wheel drum puller - 2027/2

- material hook cups: chrome molybdenum
- with five extractor hooks
- for extracting wheel hubs, up to a hole diameter of 250 mm

### Socket 1/2 character002 for removing brake drums - 2029/2

- material: chrome molybdenum
- screw special carbon tool steel
- for removing brake drum

### Handbrake wire pliers - 2030/2BI

- material: special tool steel
- for changing hand brake cable
- heavy duty double - component handles

### Brush for cleaning disk brake shoes - 2035

- for cleaning brake disc shoes prior to installing new brake linings and other metal engine parts
- extremely narrow design for those hard-to-reach spaces

### Brake spring pliers - 2037/2BI

- material: special tool steel
- drop forged, entirely hardened and tempered



2027/2



2029/2



2030/2BI



2035



2037/2BI



1

If you want to replace the brake pads with drum brakes, you must extract the brake drum.



2

The brake drum accumulates dirt and in particular a lot of rust, which must be cleaned.



3

Screw two slip-on bolts into the special threads on the brake drum.



4

Screw the slip-on bolt evenly with a suitable wrench.



5

Remove the disc spreader and mount the brake caliper on the mounting boss.



6

Each brake drum usually has two threads for screwing the slip-on bolts.



7

The extraction of the wheel hub is almost impossible without a suitable tool. Several decades ago, when a special tool could not be bought, inventive mechanics designed and produced the tool themselves.



8

Extractor hooks are mounted on the bolts to which the wheel is attached.



9

Attach the hooks on the brake drum with nuts (or bolts).



10

Insert the spindle and tighten it with a wrench until the hub is released and extracted.



## 686/2A

### Professional ball joint puller

- material: special tool steel
- drop forged, entirely hardened and tempered
- surface finish: chrome plated according to EN12540, screw blackened
- for trucks

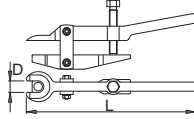

	D	L			
602369	18	260	1055	1H	1

## 2030/2BI

### Handbrake wire pliers

- material: special tool steel
- for changing hand brake cable
- heavy duty double - component handles
- jet stamp UNIOR
- Used to attach or detach the brake drum wire cable. Simply use the handbrake wire pliers to quickly tension, attach or detach the brake drum wire cable.

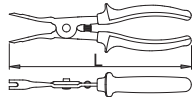

	L			
619734	234	256	4B	1

## 431/2

### Brake spring pliers

- material: special tool steel
- drop forged, entirely hardened and tempered
- loose oil hardened head, phosphated surface finish: chrome plated

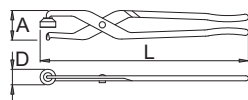

	L	A	∅D			
601554	325	53	25	423	4B	5

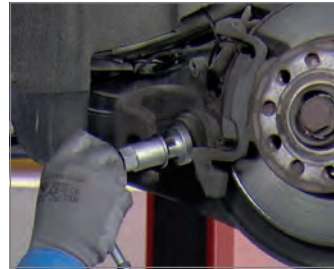

## 2033/2

### Disc spreader

- material: special tool steel
- master set of adaptors for wide range of vehicle applications
- usable for left handed thread and right handed thread
- in soft foam inserts
- The 8 adaptors that come with this tool make it useful for compressing almost all kinds of car brake pistons during brake pad replacement.

#### How to use the tool:

- Insert the tool into the brake disc shoe and use steady rotating motions to compress and simultaneously rotate the brake piston back into its shoe thus making enough space to replace the brake pads.

#### Use for:

- Audi, Fiat, Ford, Nissan, Renault, VW, Citroen, Seat, Mercedes-Benz, Opel.



	L			
619737	151	2130	1F	1

## 2033/2PB

### Disc spreader in plastic box

- material: special tool steel
- usable for left handed thread and right handed thread
- with durable plastic box, with soft foam inserts
- The 8 adaptors that come with this tool make it useful for compressing almost all kinds of car brake pistons during brake pad replacement.

#### How to use the tool:

- Insert the tool into the brake disc shoe and use steady rotating motions to compress and simultaneously rotate the brake piston back into its shoe thus making enough space to replace the brake pads.

#### Use for:

- Audi, Fiat, Ford, Nissan, Renault, VW, Citroen, Seat, Mercedes-Benz, Opel.



622637	700	1G	1

# LIGHT PRESSING OF BRAKE PISTONS

## Why do you need a special tool for compressing brake pistons?

Because the brake piston must be pushed into the starting position when replacing the brake pads.

If the brake piston is not in the starting position, the brake calipers cannot be reinstalled when replacing used brake pads due to the lack of space. Therefore, the piston must be pushed into the starting position, which can be performed most efficiently using the disc spreader.



*A suitable adapter that accurately fits the size of the brake piston must be selected.*

The brake piston has a simple task: when the driver presses the brake pedal, the brake fluid flows to the brake piston, which presses the brake pads against the brake disc. Friction is generated between the brake disc and brake pads, which causes the wheel to start braking. When the brake pedal is no longer pressed, the pressure from the brake fluid is released and the brake pads move away from the brake disc by a few tenths of a millimetre, stopping the braking.

Since this procedure is constantly repeated, the brake pads and the disc become worn over time. There are several distinctive indicators for the replacement of the brake pads, while a display on the dashboard often also indicates that the brake pads are worn and need replacing.

The brake piston is constantly being adapted to the depths of the brake pads and brake disc. With worn brake pads, the brake piston may be shifted by as much as a few centimetres from the starting position. When the insertion of a new brake pad instead of a worn pad (or even the replacement of a brake disc) is necessary, the brake piston must somehow be pushed into the starting position, otherwise the brake pad cannot be mounted on the brake calliper because of the dislodged brake piston.

When car disc brakes started replacing drum brakes, mechanics used different methods for brake pistons: usually, they tried to push the brake piston into the starting position using two iron tire levers; however, this was a demanding task due to the lack of space and the great force required, since brake fluid also had to be pushed into the tank through a small opening, together with the piston. When certain car manufacturing plants started installing disc brakes, authorised car repair shops were equipped with special tools for compressing brake pistons,

while other repair shops were forced to adapt as best they could and they often produced their own convenient tools, which were difficult to use for different brakes and sizes of brake pistons.

Unior has designed a tool that makes the compression of brake pistons a rather simple task. When replacing the brake pads (or even the brake disc), the brake calliper must be unscrewed first. Next, the body of the tool with a suitable thread (for the left or right side of brakes) for compressing the pistons must be selected. Since the brake pistons for different cars are of different sizes and the pistons for the front or rear brakes differ (the latter usually also include a built-in hand brake), the set include several (eight) socket adapters of different sizes, which fit the brake piston tightly. The proper size adapter must be selected and mounted on the body, which should be equipped with a grip plate, enabling the pushing of the piston by rotating the handle. The body of the tool with both adapters is mounted on the brake caliper and the brake piston is pushed into the starting position by screwing. An open end wrench can also be used for this task, as well as for the hand brake on rear brakes. When the piston is in the starting position, the tool may be removed. Since the piston remains in the starting position, there is enough space for the mechanic to install the calliper for the new brake pads.

When the brake caliper is installed, it is very important that the mechanic strongly presses the brake pedal several times. This causes the brake fluid to flow towards the brake piston, which presses the pads against the brake disc. When the brake pedal becomes hard, the brake pads fit on the brake disc completely. When the hard brake pedal is released (meaning that the braking is stopped), the piston and the brake pads move away from the brake disc by a few tenths of a millimetre and the sliding stops.



When replacing the brake pads, the brake calliper must first be unscrewed and removed.

When the brake pads are replaced and the brake caliper is mounted, a mechanic must first press the brake pedal strongly several times to ensure that the brake pads are completely fitted on the brake disc. If this task is not performed, the brakes will not function during the first braking.

**TOOLS USED:**

**Unior disc spreader – 2033/2 - 2033/2**

- 99900036748
- master set of adaptors for wide range of vehicle applications
- usable for left handed thread and right handed thread
- with durable plastic bag, with soft foam inserts

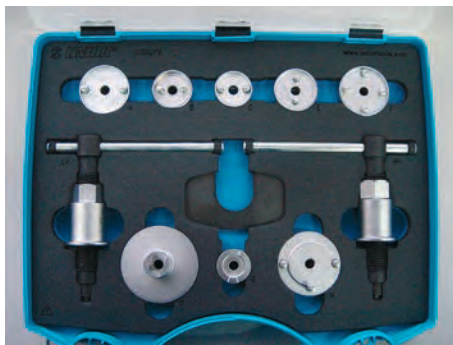

Suitable for: Audi, Fiat, Ford, Nissan, Renault, VW, Citroen, Seat, Mercedes-Benz, Opel.

The 8 adaptors that come with this tool make it useful for compressing almost all kinds of car brake pistons during brake pad replacement.



Mount the body of the tools with the suitable thread for compressing the pistons on the caliper.



Mount the grip plate for strengthening the handle.



By rotating the handle or by using a socket wrench, push the brake piston into the starting position.



Replace the brake pads or even the brake disc.



Remove the disc spreader and mount the brake caliper on the mounting boss.

## 2034/2BI

### Tool for set tyres valvelets

- material: chrome vanadium
- ergonomic heavy duty double component handle
- jet stamp UNIOR
- for setting tyre Schrader valvelets
- the handle features plastic-coated grooves that prevent sliding and thus any damage to wheel rims. The tool is appropriate for all dimensions of wheel rims.

#### How to use the tool:

1. Insert the new valvelet into the opening on the wheel rim.
2. Screw the tool on the valvelet.
3. Use the lever to pull the valvelet in the proper position on the wheel rim.

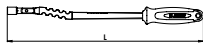

	L			
619738	325	273	4B	1

## 2035

### Brush for cleaning disk brake shoes

- for cleaning brake disk shoes prior to installing new brake linings and other metal engine parts
- extremely narrow design for those hard-to-reach spaces
- Braking causes wear on the brake pads and brake lining material to accumulate in the brake disc shoe - this has to be cleaned when replacing brake pads. The narrow design of this tool allows it to be used to clean brake disc shoes and anything else that might require such cleaning.



619739	73	TE	1



## 2036/2

### Calliper pressing tool

- material: special tool steel
- The compressing tool is used for compressing brake pistons when replacing brake pads. Useful mainly with brake disc shoes that are closed from the front. The tool is useful for compressing single or double brake pistons, mostly on front wheels. It is used to quickly and easily move brake pistons back into the shoe without damaging the piston or the shoe.

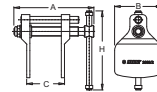

	A	B	C	H			
620224	153	90	12-97	150	1505	IG	1

## 2039/2

### Tool for internal joint steering slat

- The tool is used to quickly and easily dismount and mount the inner joint on the steering slat. The tool is pushed through the steering slat towards the joint; by rotating it, the three attachments are adjusted to the joint which is then unscrewed with the use of the S27 wrench. It can be used with diameters from Ø32 ~ 40 mm. The outer diameter of the tool's head is Ø77mm which is suitable for the opening in the bodywork through which the wrench is pushed. The tool's length of 400mm is suitable for all sizes or lengths of steering racks. It is advantageous that the use of the tool does not require the steering rack's nut to be unscrewed beforehand because the inside diameter of the tool is larger than the nut and the tool can be simply pushed through the nut.

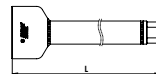

	L			
620230	400	1885	TE	1

## 2037/2BI

### Brake spring pliers

- material: special tool steel
- drop forged, entirely hardened and tempered
- loose oil hardened head, phosphated surface finish: chrome plated
- This tool is designed for mounting and dismounting brake shoe springs. Due to its compact dimensions, it allows easier reach to the brake springs than the existing Unior tool Art. 431, which is larger in size and intended for commercial vehicles, trucks and other industrial vehicles. The tool is fitted with an adjustable extension with a grooved face to prevent slipping.

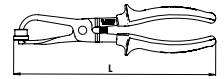

	L			
620227	244	265	4B	1



## 2042/2

### Tool for tyres valvelets

- material: special tool steel
- surface finish: chrome plated according to EN12540
- for assembling and disassembling Schrader valvelets mechanism
- one end is designed for assembling and disassembling of mechanism, other end for releasing the air

#### Advantages:

- the handle of the tools are serrated for a better grip

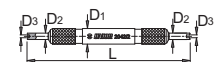

	L	D1	D2	D3			
621998	115	11	4,5	2	65	4A	1



## 210/2

### Wheel nut wrench

- material: chrome vanadium
- drop forged, entirely hardened and tempered
- surface finish: chrome plated according to EN12540

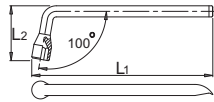

Barcode	⊕	L1	L2	Weight	Material	Quantity
600782	17	255	27	476	4A	5
600783	19	285	29.5	541	4A	5

## 212/2

### Wheel nut wrench

- material: chrome vanadium
- drop forged, entirely hardened and tempered
- surface finish: chrome plated according to EN12540
- made according to standard ISO DIN 3112

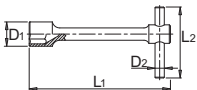

Barcode	⊕	L1	D1	L2	D2	Weight	Material	Quantity
600785	17	260	26	300	12	720	1C	1
600786	19	280	28.5	300	12	800	1C	1
600787	22	300	32	300	12	815	1C	1
600788	24	315	33.5	400	14	1280	1C	1
600789	27	355	38.5	400	20	2220	1C	1
600790	30	425	42.5	400	20	2450	1C	1
600791	32	430	48	400	20	2815	1C	1
609815	33	430	48	400	20	2875	1C	1

## 213/6

### Four way rim wrench

- material: chrome vanadium
- drop forged, entirely hardened and tempered
- lacquered
- made according to standard ISO 6788 (only metric dimension)

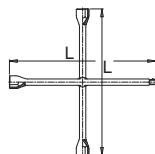
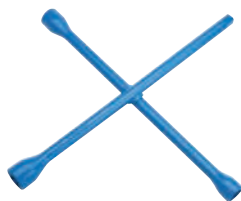

Barcode	⊕	⊕	⊕	⊕	L	Weight	Material	Quantity
600810	17	19	11/16"	1/2"	370	1355	1F	1
600811	17	19	22	1/2"	370	1430	1F	1
600809	17	19	21	23	370	1511	1F	1
600812	17	19	22	24	370	1500	1F	1
600813	24	27	30	3/4"	700	4400	1F	1
600814	24	27	30	32	700	4600	1F	1

## 300/2

### Tyre lever

- material: chrome vanadium
- drop forged, entirely hardened and tempered
- surface finish: chrome plated according to EN12540

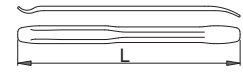

Barcode	L	Weight	Material	Quantity
617661	200	111	1C	10
601755	300	253	1C	10
601756	400	452	1C	10
601757	500	648	1C	10

## 300/2A

### Tyre lever

- material: chrome vanadium
- drop forged, entirely hardened and tempered
- surface finish: chrome plated according to EN12540

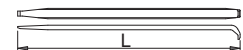

Barcode	L	Weight	Material	Quantity
601758	537	992	1C	10

## 300/2C

### Tyre lever with handle

- material: special tool steel
- surface finish: chrome plated according to EN12540
- ergonomic heavy duty double component handle

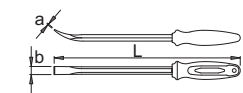

Barcode	L	a x b	Weight	Material	Quantity
613103	320	1.1 x 13	252	4B	10
613104	410	1.5 x 15	499	4B	10
613105	610	1.5 x 21	837	1C	5



### 300CCB

#### Set of tyre levers with handle



613106	3	878	TF	1
300/2C (320, 410, 610)				



### 2052/4

#### Compressor for shock absorber springs, light version

- intended for the removal of car shock absorbers
- the maximum load for the tool is up to 11000N
- UNIOR is already selling a suspension compressor for shock absorber springs (No. 2051), however, many smaller car repair shops do not need to use such a professional tool on a regular basis. This is where the light version comes in - it functions the same as the tool under art. No 2051, but has recommended load for the tool 2750 N. To prevent any bending and the springs falling out of the cups, this tool features a safeguard that enables the parts of the tool used for removing to always operate in parallel.



619733	19	4070	1G	1



### 2051/4

#### Suspension compressor for shock absorber springs

- This Unior professional tool, under article number 2051, is intended for the removal of car shock absorbers and is mainly used to compress the springs in MacPherson struts. Since the number of versions of the MacPherson strut is always increasing, the tool set contains three different pairs of grippers that almost completely cover the range of different MacPherson struts. The tool set also includes a spacer bar for conical springs, which increases the usefulness of the Shock Absorber Remover. Development of this tool took safety into account as the large forces involved in removing shock absorbers may present a risk of injury to the user. For this reason, all grippers in the set feature enlarged grip edges to firmly grip the spring in the tool thus prevent any possibility of slipping, which could injure the tool user. The recommended load for the tool is 9000 N. The maximum load for the tool is up to 37000 N. The tool is supplied in a durable PVC case that enables easier and safer transportation.
- in set 2 cups 80 - 115, 2 cups 110 - 150 in 2 cups 140 - 195



#### How to use the tool:

1. Select the appropriate cup for your spring.
2. Place the remover on the spring.
3. START compressing the shock absorber spring.

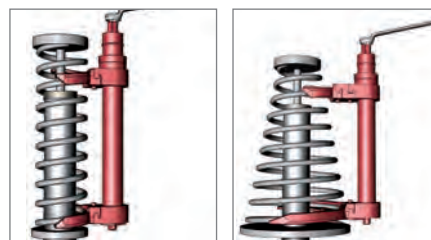

619279	300	21	80 - 195	14600
1G 1				

# REMOVING THE SHOCK ABSORBERS WITHOUT DAMAGE

## Why do you need a special tool for removing car shock absorbers?

Because the springs must be compressed and accurate grippers must be used for ensuring safety.

The removal of shock absorbers is a demanding task, as it requires a strong compression of the springs by applying great force. If the spring is not compressed with a reliable tool, it can suddenly be released and injure the mechanic who is performing the replacement of the shock absorber due to a strong force.



*The older version of a simple tool for removing shock absorbers, which is not reliable enough.*

The Unior suspension compressor for shock absorber springs is a professional tool for spring compression, a task that is necessary during the removal of shock absorbers. It is mainly used to compress the springs in the MacPherson strut. Since different cars are equipped with an increasing number of versions of MacPherson struts, the tool set contains three different pairs of grippers that almost completely cover the majority of different MacPherson struts. The tool set also includes a spacer bar for conical springs, which increases the usefulness of the shock absorber remover.

The development of the tool was especially dedicated to safety, as the large forces in the spring may present a risk of injury to the user. For this reason, all grippers in the set feature enlarged grip edges to firmly grip the spring in the tool, thus preventing it from slipping and injuring the mechanic. The recommended load for the tool is 9000 N. The maximum load for the tool is up to 37000 N.

## TOOLS USED:

### Suspension compressor for shock absorber springs - 2051/4

The tool is supplied in a durable PVC case that enables easier and safer transportation. The set includes six cups: 2 cups 80 - 115, 2 cups 110 - 150 and 2 cups 140 - 195 mm.



**SUSPENSION COMPRESSOR  
FOR  
SHOCK ABSORBER SPRINGS**

**UNIOR®**  
**Art. 2051**

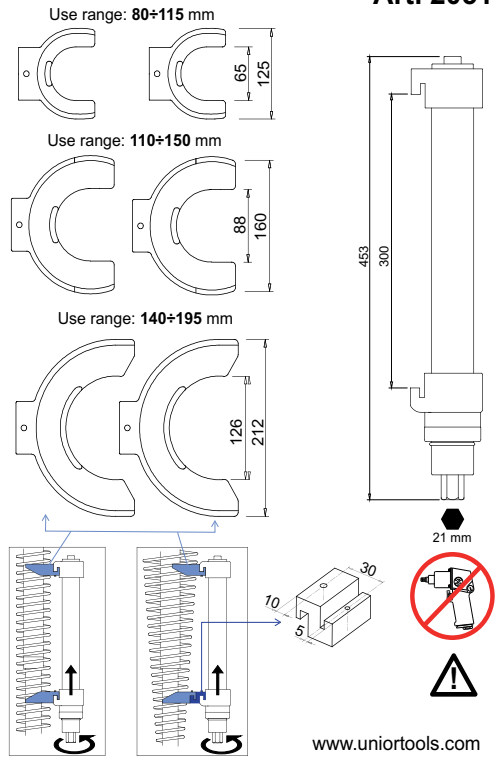



2151/2BI

Spark plug pliers

- material: special tool steel
- for removing spark plugs
- heavy duty double - component handles
- jet stamp UNIOR
- This tool is intended for the safe and quick removal of spark plug covers without damaging them. As an added feature, the tool allows you to cut power supply cables or compress cable attachments.

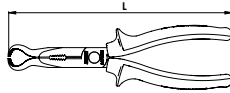

	L			
619732	192	206	4B	1

631

Car light tester 6 - 12/24 V

- Use only on proven automobile installations for voltages of up to 12V and up to 24V.
- Use for other purposes or at different voltages may be life threatening.
- The product may not be used for verifying the grid voltage!

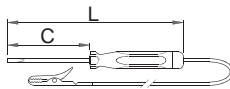

	V	a x b	C	L			
601688	6 - 12	0.5 x 3.0	60	140	25	TE	10
601689	6 - 24	0.6 x 3.5	90	180	25	TE	10

631B

Car light tester 6 - 12/24 V

- Indispensable tool in every car workshop.
- Safety cover for the tip of the tester, intended to prevent injuries to users.
- Used for checking electrical installations in all 6 - 24 V systems in the car.

USAGE:

- Connect the clip to any ground point.
- Pierce the wire insulation with the tip of the tester to find live wires.
- Keep piercing the insulation along the wire until the tester stops being illuminated, which indicates that the wire is broken.
- Use for other purposes or at different voltages may be life threatening.
- The product may not be used for verifying the grid voltage!

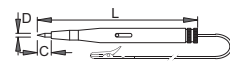

	V	C	D	L			
619856	6 - 24	12	1.8	110	38	TE	10

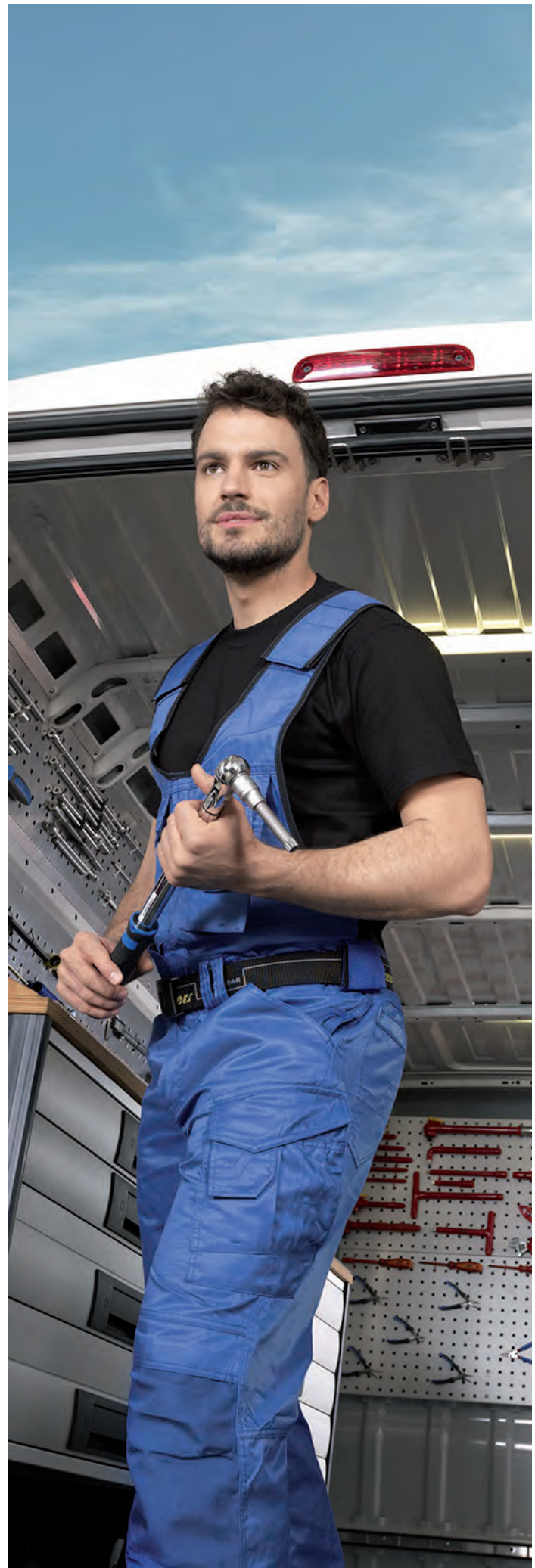

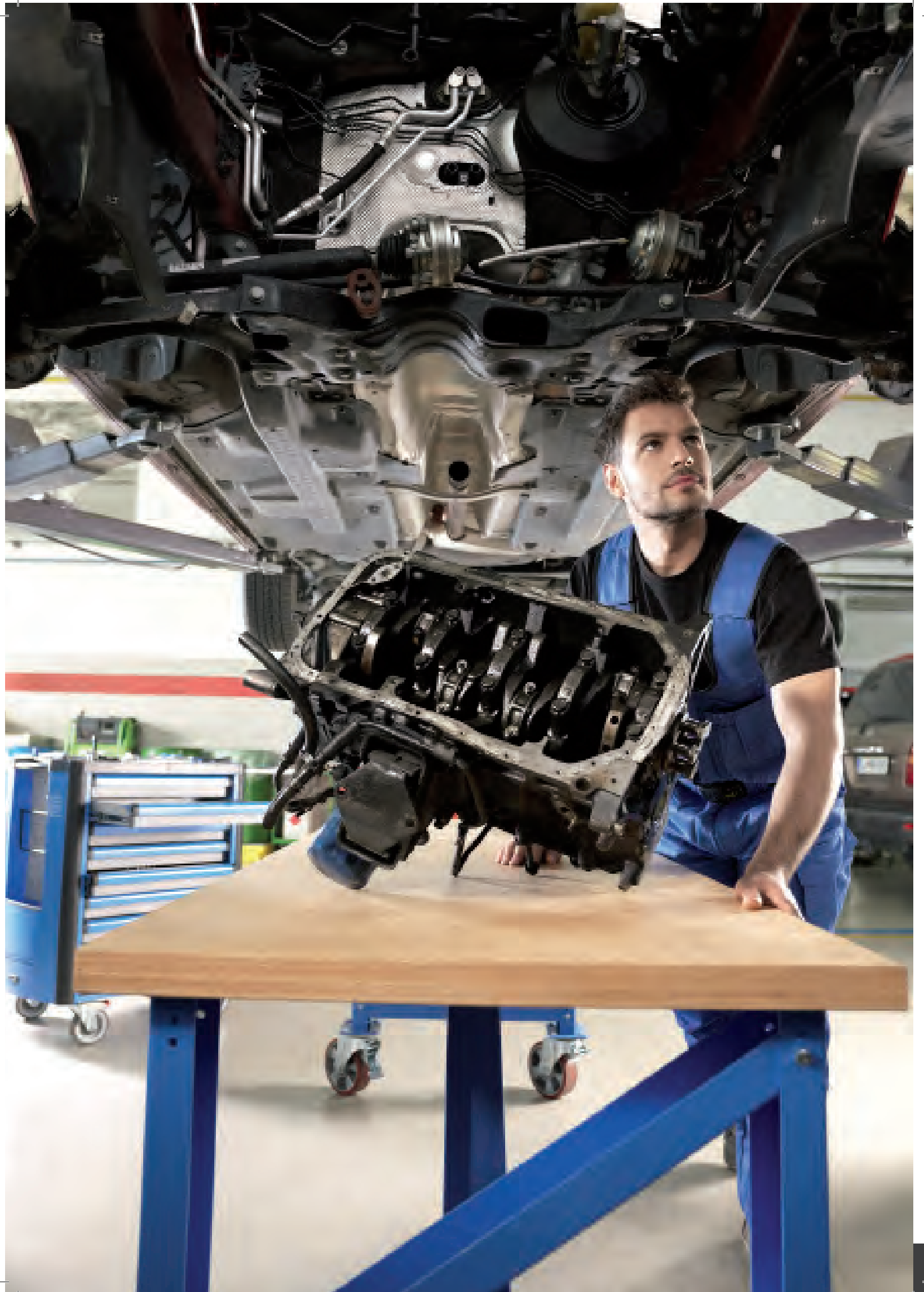

**185/2**

**Spark plug wrench**

- material: special tool steel
- surface finish: chrome plated according to EN12540

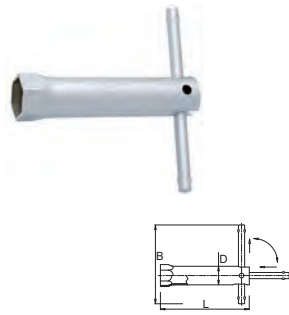

Barcode	Icon	D	L	B	Weight	Material	Quantity
600771		16	19	145	120	182	1E 10
607956		19	22	115	120	199	1E 10
600772		21	24	115	120	177	1E 10
600773		21	24	180	120	248	1E 10



**186BI**

**Set of spark plug sockets with accessories 3/8"**



Barcode	Icon	Quantity	Weight	Material	Quantity
619403		4	560	1F	1

238.1/1FBI (3/8"), 238.4/2 (3/8" x 45, 3/8" x 75), 186.4/2 (16)

**186BI**

**Set of spark plug sockets with accessories 3/8"**



Barcode	Icon	Quantity	Weight	Material	Quantity
619401		4	627	1F	1

238.1/1FBI (3/8"), 238.4/2 (3/8" x 45, 3/8" x 75), 186.4/2 (21)

**186BI**

**Set of spark plug sockets with accessories 3/8"**



Barcode	Icon	Quantity	Weight	Material	Quantity
619402		4	615	1F	1

238.1/1FBI (3/8"), 238.4/2 (3/8" x 45, 3/8" x 75), 186.4/2 (19)

**186.4/2**

**Spark plug socket 3/8"**

- material: chrome vanadium
- drop forged, entirely hardened and tempered
- surface finish: chrome plated according to EN12540

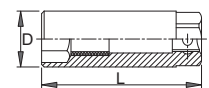

Barcode	Icon	D	L	Weight	Material	Quantity	
620819		13	17.9	63	68	4B 10	
603193		16	22	63	19	68	4B 10
620820		18	24.7	63	22	68	4B 10
603192		19	26	63	22	68	4B 10
600776		21	27	66	19	68	4B 10

**186.4/2A**

**Spark plug socket 3/8"**

- material: chrome molybdenum
- drop forged, entirely hardened and tempered
- surface finish: chrome plated according to EN12540



Barcode	Icon	D	L	Weight	Material	Quantity	
622513		14	18	63	17	58	4B 10

**2178/2BI**

**Relay puller pliers**

- material: special tool steel
- heavy duty double - component handles
- for safe installation and removal of cubic electrical relays on most vehicles
- tips are thin and serrated for better grip of the relay



Barcode	L	Weight	Material	Quantity
622585	232	250	4B	1



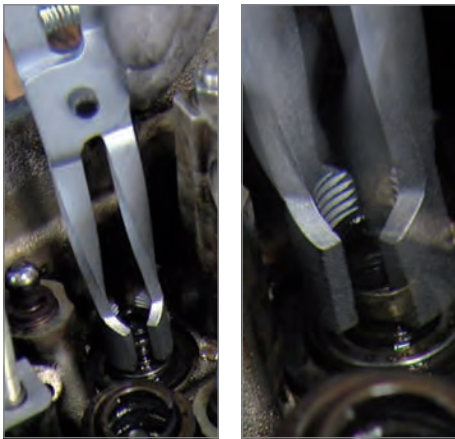

### 2201/2BI

#### Valve seal removal pliers

- material: special tool steel
- surface finish: chrome plated to standard EN12540
- extra long nose
- extra slim form allows removal of valve-stem oil-seals in deep engine block places
- for valve stem sealing rings
- jet stamp UNIOR
- heavy duty double - component handles
- Valve seal removal pliers - Narrow design allows access to valve stem seals even in the tight confines of 4 valve per cylinder heads. Features serrated tips for a positive grip on the seal, heat-treated steel construction and cushioned handles.

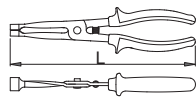

	L				
619721	275	287	4B	1	

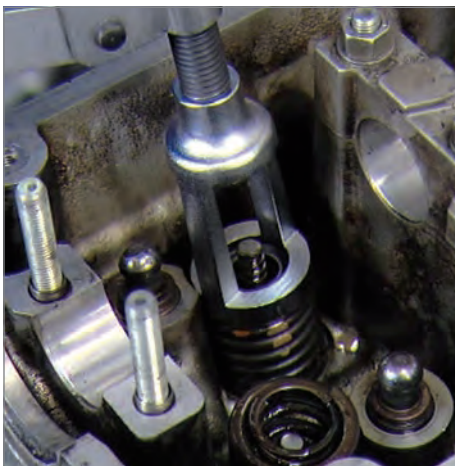

### 2202/2BI

#### Valve spring compressor

- material: special tool steel
- entirely hardened and tempered
- surface finish: chrome plated
- suitable for almost all engines due to its wide range of adjustment
- valve spring compressor not include pressure pieces
- 4 pressure pieces (article 2202.1) allows us working on almost all engines and are available as spare parts
- using its very fast and easy with lever blockade
- after adjusting the tool for the first valve, the speed of work increases as readjusting is not necessary for subsequent valves
- adjustable handles enable desired pressure on the spring
- extra large throat for larger engines
- This tool is used to attach and detach valve springs and features a self-locking lever and quickly-adjustable fittings to allow it to be used with all kinds of engines.

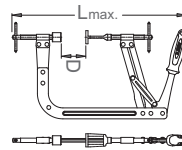

	L	D				
619722	430	20 - 250	1810	1G	1	

### 2202.1/2

#### Pressure pieces for valve spring compressor

- material: special tool steel
- entirely hardened and tempered
- dimensions 21,25 for motorbikes, 21,25,30,35,43 for cars



	D				
620567	21	46	1E	1	
620208	25	54	1E	1	
620209	30	62	1E	1	
620210	35	84	1E	1	
620211	43	106	1E	1	

### 2206

#### Universal clutch aligner

- designed for most vehicles, with single plate clutches
- for clutch up to: 15 - 28 mm
- easy to use
- The tool under art. No. 2206 is the only universal clutch aligner that allows you to align almost any standard passenger car clutch. This is done directly between the clutch plate and the pressure plate by using the universal clutch aligner to join them together. After the clutch aligner is removed, both parts of the clutch are joined together and aligned with regard to their axes.



619730	211	1G	1	



2205

Piston ring compressor

- use to install pistons on most passenger cars
- high quality construction with spring steel wraps
- with safety adjusting screws
- available in a wide range of sizes
- This tool is used to install pistons and piston rings into engine cylinders. Different sizes are available.

How to use the tool:

- Insert the piston and any piston rings into the tool, position the tool at the opening and use it to insert/push the piston and any piston rings into the cylinder.

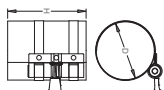

Barcode	H	D	D	W	W	W
619725	50	1 3/4" - 3 1/2"	40 - 90	178	TG	1
619726	80	2 1/4" - 5"	57 - 125	291	TG	1
619727	80	3 1/2" - 7"	90 - 175	320	TG	1
619729	165	3 1/2" - 7"	90 - 175	587	TG	1

2207/2

1/2" square drive socket for diesel engine injectors

- suitable for a variety of diesel engines
- Socket for diesel engine injectors is used for removing and replacing diesel injectors without damaging fuel lines.

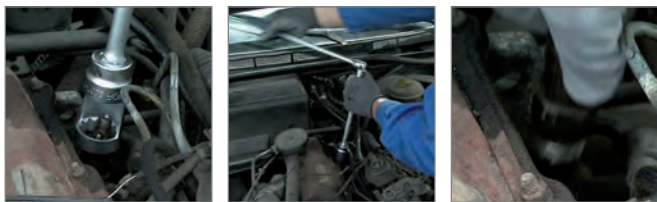

Barcode	W	W	W	W	W
619731	12P - 22mm	diesel	162	4B	5
619887	6P - 22mm	diesel	224	4B	5
619888	12P - 27mm	BMW. Fiat. Ford	217	4B	5
619889	12P - 28mm	Scania. Volvo HGV	227	4B	5

2204

Kit for controlling cam belt tension

- very easy to use
- a precise progressive setting button
- the two-sided scale allows reading on both sides
- This tool is used to set the cam belt tension. It is suitable for most types of car cam belts.

How to use the tool:

1. Select the proper tool position according to the manufacturer's recommendations.
2. Position the tool for controlling the cam belt tension
3. Refer to the attached table to find the proper cam belt tension.
4. Set the tool for controlling the cam belt tension to the proper value.
5. Verify the aeration of the cam belt.
6. Perform the necessary adjustments on the cam belt tensioner.
7. Position the tool for controlling the cam belt tension again and verify that the cam belt is properly tensioned.



Barcode	L	W	W	W
619724	98	393	TG	1

2203/2BI

Tool for rotating camshaft pulley

- material: chrome vanadium
- pin material: special carbon tool steel
- for holding pulleys on camshafts, injection pumps
- for timing pulleys, span from 24 to 160 mm
- available pin dimensions: Ø5.7, Ø7.7, Ø9.7, Ø11.7, Ø18
- heavy duty double - component handles
- jet stamp UNIOR
- Used to hold the camshaft pulley in place so that the center screw can be unscrewed prior to removing the camshaft pulley. This easy-to-use tool is intended for all types of camshaft pulleys.



Barcode	L	W	W	W
619723	525	1435	IF	1

# HOLD, UNSCREW AND REMOVE THE PULLEY

## Why do we need a special tool for removing pulleys?

The pulley has to first be held so that the centering screw can be unfastened and then pulling attachments can be mounted into the front grooves.

Cars usually have several pulleys that often have to be removed due to various repairs or maintenance of devices that the pulleys are driving. When an individual pulley has to be removed depends on the structure of the engines. But in all tasks, workers face a known and in almost all cars exactly the same difficulty - lack of space for unfastening and removing the pulley.



*When removing pulleys, mechanics have difficulties because usually there is not enough room. This can be resolved by using a special tool. With the tool for the rotation of the drive pulley, the pulley can be held so that the screw can be unscrewed and the pulley removed with a suitable puller.*

In the majority of engines, the camshaft pulley has to be removed if any larger task has to be done on the engine. High-pressure pumps for fuel supply are driven by pulleys that have to be removed if the pump needs repair or replacement. It is similar with water pumps where the pulley also has to be removed to repair or replace the pump. In some engines, the pulley has to be removed even when replacing the cogged belt. In some vehicle models, the pulley of the engine shaft also has to be removed.

Almost in no vehicle is there enough room for a comfortable removal of pulleys. Often, there is so little room that the tools for holding and removing the pulley cannot be used: in these cases, the engine has to be removed from the engine bearings and lifted with a lift from the engine space. But in such cases, the pulley cannot be removed without appropriate tools.

Unior manufactures tools for unfastening pulleys for the rotation of the drive pulley and two different pulley pullers. The tool for the rotation of drive pulleys can be used to unscrew the centering screw with which the pulley is fastened to the drive axle, and the puller to remove the pulley which is attached to the axle.

The use of the tool for the rotation of the drive pulley is relatively simple if there is enough room next to the pulley that we wish to remove. On their front side, most pulleys have various grooves (clearances) made for easier installation and removal of pulleys. There are also pulleys that do not have such grooves and a different tool is required to hold (block) the pulley.

But as mentioned above: most pulleys have grooves (slots) into which

attachments are inserted in the shape of the grooves. Two suitable attachments have to be chosen and fastened (screwed in) into both spokes of the tool for the rotation of the drive pulley, then the attachments should be inserted into the grooves of the pulley. When the attachments fit with the groove, the pulley is held with a tool that has a long enough handle, and the centering screw should be unscrewed with a torx key. The tool can be used for turning right or left (unscrewing/screwing of the pulley), and the attachments can be installed onto one or the other side of both spokes (installation required available room). When installing the pulley onto the axle, the procedure is the same; to fasten it, a torque wrench is required on which the tightening force suitable for the screw should be set. To hold the drive pulley, use a special tool: it has multiple variously shaped attachments that fit various grooves on the pulley.

Unior's tool for holding (rotation) the pulley is robust enough to hold larger pulleys. It has two relatively long spokes where attachments are located, which according to the expert who tested the tool is good because the tool can also be used where there is relatively little space for intervention; otherwise the work might be impeded by the robust and protruding screw that connects both spokes.

When the screw is unscrewed, the pulley must be removed. Pulleys are mounted onto the axle tapered and have a groove that fits the bolt on the axle so that the pulley on the axle does not slip. Unior has two pullers for removing the pulley, a standard and an universal one. The first has (symmetrically) adjustable spokes, the other has grooves for various mounting of the three attachments for removing. Both pullers require that the attachments that have deepened edges are placed onto front grooves of the pulley so that the edge of the attachment fits with the edge of the groove on the pulley. When the attachments are installed

and the attachment edges correspond to the groove edges, the central screw has to be fastened so that it is propped on the axle, and when the screw overcomes the force with which the pulley is mounted onto the axle, the pulley releases and is removed. When removing the pulley with the universal puller, the puller can also be held with a wrench that prevents the pulley from rotating during the fastening of the central screw. With one wrench, we thus hold the tool and fasten the removing screw with the other.

## A tool for holding and removing pulleys

### TOOLS USED:

#### Tool for rotating camshaft pulley - 2203/2BI

- material: chrome vanadium
- pin material: special carbon tool steel
- for holding pulleys on camshafts, injection pumps
- for timing pulleys, span from 24 to 160 mm
- available pin dimensions: Ø5.7, Ø7.7, Ø9.7, Ø11.7, Ø18
- heavy duty double - component handles

Used to hold the camshaft pulley in place so that the center screw can be unscrewed prior to removing the camshaft pulley. This easy-to-use tool is intended for all types of camshaft pulleys.

#### Timing pulley puller - 2210/2

- material: special tool steel
- for removing pulleys with 3, 6, 9 slots

This tool is designed for removing drive pulleys with face grooves. The tool removes a pulley absolutely free of any risk of damage. The tool is adaptable to different pulley diameters, as the legs are adjustable.

#### Universal timing pulley puller - 2210/2A

- surface finish: chrome plated according to EN12540, screw blackened
- for removing all types of pulleys with 2, 3, 4, 5, 6, 7, 8, 9 slots



2203/2BI



2210/2A



2210/2



Insert the attachments screwed onto both spokes of the tool into grooves on the front side of the pulley.



Hold the pulley with the tool and unscrew the centering screw with a torx key.



When installing the pulley, the procedure is the same as when unscrewing, only the fastening has to be done with a torque wrench.



When the centering screw is unscrewed, the puller can be mounted.



When the attachments are inserted into the grooves, tighten the screw until the pulley releases from the axle.



Attachments on the puller must fit with their edge to the edges of the grooves on the pulley.



The universal puller provides several possibilities of attaching the attachments because the tool has several slots for them.

2208

**Ribbed driver pulley puller**

The puller is used to dismount pulleys of various shapes, in particularly those used in passenger cars. The tool is suitable for pulleys with the following diameters: min. Ø45 mm; max. Ø235 mm. The puller is useful for effectively removing pulleys from hard-to-reach areas, and especially without the risk of any damage to the pulley. The tool has two types of pulling paws, suitable for various types of pulleys.

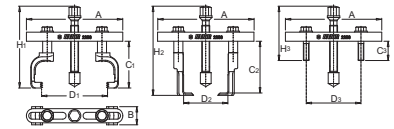

Barcode	A	B	C1	C2	C3	D1	D2	D3	H1	H2	H3	Weight	Material	Quantity
620223	171	32	60 - 82.5	69 - 91	34	80 - 150	40 - 120	40 - 150	200	213	152	2340	1G	1

**2208.1/4**

**Spindle for 2208**

- material: special tool steel
- surface finish: blacken



Barcode	M	L	S	Weight	Material	Quantity
623959	Tr 14 x 1,5	110	17	170	1V	1

**2208.2B/2**

**Long pulling arm for 2208**



Barcode	Weight	Material	Quantity
623963	175	1V	1

**2208.1A/2**

**Screw for arm for 2208**



Barcode	M	L	S	Weight	Material	Quantity
623960	M 10 x 1,5	30	15	35	1V	1



**2208.1B/2**

**Pulling screw for 2208**



Barcode	M	L	S	Weight	Material	Quantity
623961	M 10 x 1,5	60	15	45	1V	1

**2208.2A/2**

**Short pulling arm for 2208**



Barcode	Weight	Material	Quantity
623962	130	1V	1

**2209**

**Alternator combination socket**

This two-part tool for the alternator allows the easy dismounting and mounting of the alternator pulley for the purposes of pulley replacement or alternator repair. The alternator is blocked by means of a 10 mm XZN multispline insert; simultaneously, the pulley retaining screw on the shaft is released/tightened. The tool is available as a 1/2" socket key with a XZN - M10 bit and as a 1/2" socket key with a TX50 bit.

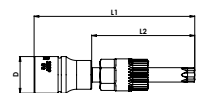

Barcode	Bit	D	L1	L2	Weight	Material	Quantity
620225	M 10	23.8	113	75	178	4B	1
620948	TX 50	23.8	113	75	176	4B	1



## 2210/2

### Timing pulley puller

- material: special tool steel
- entirely hardened and tempered
- surface finish: chrome plated according to EN12540, screw blackened
- for removing pulleys with 3, 6, 9 slots
- This tool is designed for removing drive pulleys with face grooves. The tool removes a pulley absolutely free of any risk of damage. The tool is adaptable to different pulley diameters, as the legs are adjustable.

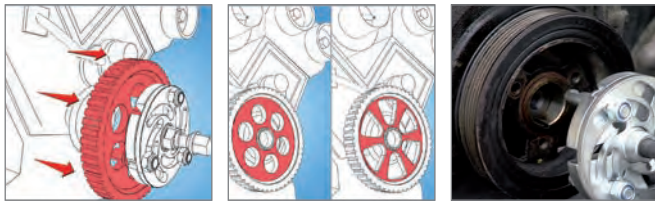
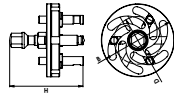

	B	D	H			
620226	100	48 - 82	135	1085	1G	1

## 2210/2A

### Universal timing pulley puller

- material: special tool steel
- entirely hardened and tempered
- surface finish: chrome plated according to EN12540, screw blackened
- for removing all types of pulleys with 2, 3, 4, 5, 6, 7, 8, 9 slots
- This tool is designed for removing drive pulleys with face grooves. The tool removes a pulley absolutely free of any risk of damage. The tool is adaptable to different pulley diameters, as the legs are adjustable.

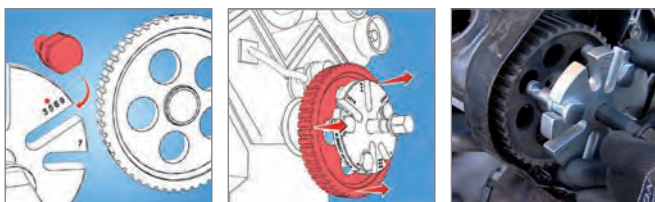
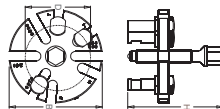

	B	D	H			
621780	100	48 - 82	135	750	1G	1

## 2210.1/4

### Spindle for 2210/2

- material: special tool steel
- surface finish: blacken



	M	L	S			
623964	Tr 14 x 1,5	82,5	17	140	1V	1

## 2210.2/2

### Arm for 2210/2



623966	50			1V		1

## 2210.2/2A

### Arm for 2210/2A



623967	50			1V		1

## 2210.1/4A

### Spindle for 2210/2A

- material: special tool steel
- surface finish: blacken



	M	L	S			
623965	Tr 14 x 1,5	82,5	17	140	1V	1

## 2213/2BI

### Angle gauge

- this tool is used for screws on the heads of motors where car manufacturers prescribe that, as well as fastening the screws to the prescribed torque, fastening at a certain angle is also required
- if your space is limited, you can also use an extension to obtain the required height
- the scale is 360°, divided into 2° angles

#### How to use the tool:

- hold the angle scale by its small handle to avoid rotation during screw joining, set the indicator to zero and then fasten the screw at the prescribed angle with another tool from the 1/2" product range (e.g. a hinge handle which is longer, because the forces are considerable)



	L	B	A	C		
622815	270	75	80	63	428	4B 1

200/2

Starter and block wrench

- material: chrome vanadium
- drop forged, entirely hardened and tempered
- surface finish: chrome plated according to EN12540

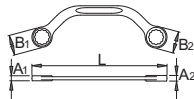

Barcode	Icon	L	B1	B2	A1	A2	Weight	Icon	Icon
600671		11 x 13	150	16.5	19	7	8.5	54	4A 10
600672		13 x 17	185	19.2	24.2	8.7	10.3	99	4A 10
600673		14 x 17	185	20.5	24.2	8.7	10.3	104	4A 10
600674		15 x 16	185	21.6	23.6	8.7	10.3	104	4A 10
600675		15 x 17	185	21.6	24.2	8.7	10.3	101	4A 10
600676		19 x 22	230	27.2	31.8	10	11.5	178	4A 10

200/2CB

Set of starter and block wrenches in carton box



Barcode	Icon	Weight	Icon	Icon	Icon
600677		11 - 22 / 5	605	1F	1

200/2 (11 x 13, 13 x 17, 14 x 17, 15 x 16, 19 x 22)

2211

SAC Clutch tool set

- material: special tool steel
- entirely hardened and tempered
- This SAC clutch tool set can be used to quickly and professionally dismantle and install SAC clutches. Usually, SAC clutches have 3 spokes, however some vehicles use 4-spoked versions (e.g. Mercedes A since 2004). Suitable for almost all SAC clutches (3- and 4-spoked), e.g. VW-Audi, BMW, Mercedes, Volvo, Opel, Renault, etc.

Advantages:

1. pre-tightening of the thrust plate during dismantling and installing (important for preventing strain on the clutch),
  2. centering the clutch plate in the direction towards the guide bearing or towards the thrust plate,
  3. withdrawing the adjusting ring with the withdrawal tools.
- Dimension of box: 393 x 331 x 95

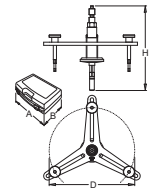

Barcode	A	B	D	H	Weight	Icon	Icon
620233	305	268	322	267	7400	1G	1

2301SOS1

Set of automotive tools in SOS tool tray

- for changing spark plugs



Barcode	Icon	Weight	Icon	Icon
623122		10	1455	1F 1

186.4/2 (13, 16, 18, 19, 21), 186.4/2A (14),  
238.1/1FBI (3/8"), 238.4/2 (3/8" x 45, 3/8" x 75), 2151/2BI (192), vI2301SOS1 (188 x 364 x 30)

vI2301SOS1

SOS tool tray for 2301SOS1

Barcode	B	L	H	Weight	Icon	Icon
623103	188	364	30	57	1V	1

2301SOS2

Set of automotive tools in SOS tool tray

- for disassembling hub and brake drum



Barcode	Icon	Weight	Icon	Icon
623123		1	5190	1F 1

2027/2 (250), vI2301SOS2 (374 x 364 x 30)

vI2301SOS2

SOS tool tray for 2301SOS2

Barcode	B	L	H	Weight	Icon	Icon
623104	374	364	30	94	1V	1

2301SOS3

Set of automotive tools in SOS tool tray

- for break systems



Barcode	Icon	Weight	Icon	Icon
623124		4	955	1F 1

2029/2 (M 8), 2030/2BI (234), 2035, 2037/2BI (244), vI2301SOS3 (188 x 364 x 30)

vI2301SOS3

SOS tool tray for 2301SOS3

Barcode	B	L	H	Weight	Icon	Icon
623105	188	364	30	57	1V	1

# TOOLS FOR SELF-ADJUSTABLE CLUTCH

## Why do we need special tools when replacing the SAC self-adjustable clutches?

Replacing the clutch requires precise work that can only be carried out with a special tool. Without it, the thrust plate and the clutch disc cannot be mounted and the clutch cannot be centered.

Repairing the clutch can be categorized as slightly more demanding and time-consuming tasks that one faces when working in car workshops. There are of course several types of clutches and often a self-adjusting clutch (SAC) is built into private cars and light vans. It is mainly a part of stronger vehicles with diesel motors and a double or floating flywheel. Its service life is longer and changing the gear is more comfortable. Repairing the clutch without a special tool is almost impossible, because it is not possible to install the new discs and thrust plates of the clutch.



*For the purpose of reliable operation, workers almost always install a new disc and a new thrust plate of the clutch, often also a new thrust bearing and even the flywheel. Used parts do not guarantee proper operation of the clutch.*

Many vehicles are equipped with SAC clutches (Self Adjusting Clutch), e.g. VW, Audi, BMW, Mercedes, Volvo, Opel, Renault, etc. vehicles. The manufacturers of SAC clutches claim that there is no need to throw away the thrust plate and the clutch plate when the clutch does not function well. Sometimes its parts only have to be thoroughly cleaned according to instructions and then reassembled. According to experienced workers, the number of such tasks is decreasing, because sooner or later it becomes evident that a partially repaired clutch cannot perform its function for long. Therefore, they recommend that a new clutch plate (disc) and thrust plate of the clutch are installed; if they provide a warranty for the functioning of the clutch, they also always replace the thrust bearing and if they determine that it is airy they also replace the flywheel.

Usually, the SAC clutches have three spokes, the newer ones four. The number of spokes is determined by the placing of the mounting screws of the thrust plate. With three-spoked clutches, three fastening screws of the thrust plate must first be unscrewed; they are arranged on the plate so that there are 120 degrees between them. The same procedure applies to four-spoked versions where four thrust screws must be unscrewed that are arranged on the plate so that there are 90 degrees between them. In their place, suitable bolts have to be screwed in from the tool for the self-adjusting clutch (bolts with sizes M6, M7 and M8). When the bolts are in place, the three-spoked (or four-spoked) tensioner has to be mounted on them and screwed with ribbed nuts that are a part of the tool set. The nuts have to be screwed in so that the outer surface of the nuts and the edges of the bolts are completely level. Then the spindle has to be inserted and screwed in with the wrench (S24) so that the diaphragm spring is in the limiter (the adjusting ring is blocked). Now all the screws of the thrust plate can be unscrewed. When the screws are unscrewed, unscrew the tensioner spindle so that the spring goes into its original position. The tool must be removed so that the thrust plate and the clutch plate can also be removed. When the bolts are unscrewed, the clutch thrust plate can be removed and then the clutch plate.

Depending on the wear-out of components of the clutch or defects due to which the clutch does not function well, we decide on performing the following procedure. If we once again install the already used disc and thrust plate, care

should be taken regarding the position of the adjusting ring in the thrust plate. It should not be turned (back) into its starting position as is done when mounting a new part; it must remain in the same position as before the dis-assembly of the clutch, because the clutch is already worn out. When installing a new plate and a new thrust plate, the adjusting ring does not have to be adjusted because it is already set to the starting position.

When installing a new clutch plate (disc), it has to be centered with the flywheel. In the center of the flywheel, a socket of a suitable size has to be inserted (the kit contains several sockets) that is screwed beforehand into the tool for centering. The centering tool has a tensioning nut for centering with which we determine the correct position of the disc. Then a new thrust plate should be positioned onto the flywheel. Now, once again screw in the screw bolts into the flywheel, place the tensioner onto the bolts and screw in the screw nuts (the surface of the nuts and the edges of the bolts must be level). Then, place the spindle and screw it so that the diaphragm spring is in the limiter. Then screw in the fastening screws of the thrust plate, unscrew the spindle (the diaphragm spring is once again in the original position), unscrew the nuts, remove the tensioner, unscrew the bolts and screw the remaining fastening screws into the places where the bolts were. Remove the tool for centering the clutch by releasing the tensioning nut.

When inserting the disc and the thrust plate, the following is also important: with the tool for reversing, which is part of the set, set the return spring on the thrust plate. When the disc is removed, the thrust plate has to first be once again fastened and then the tensioner and the spindle have to once again be installed. The spindle should be fastened for so long until the adjusting ring in the thrust plate starts turning. Then the reversing tool should be mounted into the opening of the thrust plate at the return spring. Then once again unscrew the spindle of the tensioner and disassemble the tensioner. Remove the thrust plate on which the tool for reversing is located. Now, we can once again insert the disc and center it and finish the procedure according to the same procedure when inserting the new parts of the clutch.

## TOOLS USED:

### SAC Clutch tool set - 2211

- material: special tool steel

This SAC clutch tool set can be used to quickly and professionally dismantle and install SAC clutches. Usually, SAC clutches have 3 spokes, however some vehicles use 4-spoked versions (e.g. Mercedes A since 2004). Suitable for almost all SAC clutches (3- and 4-spoked), e.g. VW-Audi, BMW, Mercedes, Volvo, Opel, Renault, etc.



#### Advantages:

1. pre-tightening of the thrust plate during dismantling and installing (important for preventing strain on the clutch),
2. centering the clutch plate in the direction towards the guide bearing or towards the thrust plate,
3. withdrawing the adjusting ring with the withdrawal tools.



Sockets, ribbed nuts, tools for centering and a tensioner.



Tool for return spring.



Bolts of various sizes.



Tensioning spindle.



Choose a socket of a suitable size.



The socket size should suit the flywheel.



Insert the centering tool into the disc.



Fasten the tensioning screw so that the tool completely fits the disc.



Insert the disc with the tool into the spindle.



Install the thrust plate and the tensioner with the spindle.



Fasten the nuts onto the tensioner.



Fasten the tensioner spindle with a suitable wrench.



Insert the tool for the tensioning screw.

### 2301SOS4

#### Set of automotive tools in SOS tool tray

- for clips and clamps (spring, clic, oetiker) hoses



623125	7	2650	TF	1

2077/2BI (235), 2078/2BI (230), 2079/2BI (206), 2080/2BI (190), 2081/3 (285), 2089/2BI (230), vl2301SOS4 (374 x 364 x 30)

### vl2301SOS4

#### SOS tool tray for 2301SOS4

	B	L	H			
623106	374	364	30	94	TV	1

### 2301SOS5

#### Set of automotive tools in SOS tool tray

- for changing oil filters



623126	4	1780	TF	1

175/2 (8 x 10), 205/2 (220 x 60 x 140), 206/2 (220 x 60 x 140), 1976/2 (60), vl2301SOS5 (188 x 364 x 30)

### vl2301SOS5

#### SOS tool tray for 2301SOS5

	B	L	H			
623107	188	364	30	57	TV	1

### 2301SOS6

#### Set of automotive tools in SOS tool tray

- for changing oil filters



623127	12	2040	TF	1

© 1977/6 (27 x 6, 32 x 6, 36 x 6, 66 x 6, 65 x 14, 74 x 15, 75 - 77 x 15, 76 x 12, 76 x 14, 86 x 16, 86 x 18, 96 x 18), vl2301SOS6 (374 x 364 x 30)

### 2301SOS7

#### Set of automotive tools in SOS tool tray

- for general maintenance tasks



623128	6	3280	TF	1

2091 (250), 2087 (1), 2086 (150), 2085 (510), 2084 (240), 264 (1/2" x 28 - 210), vl2301SOS7 (564 x 364 x 30)

### vl2301SOS7

#### SOS tool tray for 2301SOS7

	B	L	H			
623109	564	364	30	138	TV	1

### 2301SOS8

#### Set of automotive tools in SOS tool tray

- for dismantling ribbed pulleys



623129	1	2135	TF	1

2208 (171), vl2301SOS8 (188 x 364 x 30)

### vl2301SOS8

#### SOS tool tray for 2301SOS8

	B	L	H			
623110	188	364	30	57	TV	1

### vl2301SOS6

#### SOS tool tray for 2301SOS6

	B	L	H			
623108	374	364	30	94	TV	1

### 2301SOS9

#### Set of automotive tools in SOS tool tray

- for changing tires



623130	4	1025	TF	1

2042/2 (115), 2034/2BI (325), 2035 ( ), 2028/2P (250), vl2301SOS9 (188 x 364 x 30)

### vl2301SOS9

#### SOS tool tray for 2301SOS9

	B	L	H			
623111	188	364	30	57	TV	1

### 2301SOS10

#### Set of automotive tools in SOS tool tray

- for changing tires



623131	15 - 21 / 8	4605	TF	1

1561 (1/2"), 231/4PL (17, 19, 21), 231/4 6p (15, 17, 19, 21), vl2301SOS10 (188x364x30)

### vl2301SOS10

#### SOS tool tray for 2301SOS10

	B	L	H			
623112	188	364	30	57	TV	1



# 1011CEV4 (624137)

## Tool set 127 pcs with tool carriage 940EV4

static load capacity of carriage without wheels: 1600kg



Basic tool set for maintenance in car repair workshops, agro services and maintenance in the industry.

### 940EV4 Tool carriage Eurovision

- Opening and closing of drawers is very simple due to the uniform solution - drawer handle on the upper side enables users a synchronic grip and opening of a carriage drawer.
- Drawer closing mechanism prevents unwanted opening of drawers.
- Possibility to add accessories.
- 7 drawers (five dimensions 563x365x70mm, two dimensions 563x410x150mm)

maximum capacity of each drawer: 40kg



drawers with ball-bearing slides



locking system

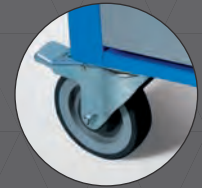

new wheels dia. 125mm, for improved agility and stability

#### 964/49SOS (623990)



660/6 (150, 200), 642/6 (5), 641/6 (3, 4, 5, 6), 300/5C (320), 701 (0.05 - 1 x 20), 753P (150), 556A (160), 710P (3), 2087 (1), 2035 (1), 760H1/2S (200), 764H1/2S (200), 763H1/2S (200), 761H1/2S (200), VL964/49SOS (564 x 364 x 30)

#### 964/46SOS (623987)



120/1 (6, 7, 8, 9, 10, 11, 12, 13, 14, 15, 16, 17, 18, 19, 21, 22, 24), 220/3 (1.5, 2, 2.5, 3, 4, 5, 6, 8, 10), 605TBI (0.4x2.5x75, 0.5x3.0x80, 0.6x3.5x100, 0.8x4.0x100, 1.2x6.5x150, 1.2x8.0x175), 615TBI (PH 1 x 80, PH 2 x 100), 627TBI (1.0 x 5.5 x 25), 626TBI (PH 2 x 25), VL964/46SOS (564 x 364 x 30)

#### 964/47SOS (623988)



188/2 6p (5, 5.5, 6, 7, 8, 9, 10, 11, 12, 13, 14), 187/2HX (3, 4, 5, 6, 7), 187/2PH (PH 1, PH 2), 187/2SL (0.8 x 4, 1 x 5.5, 1.2 x 7), 187/2TX (TX 8, TX 10, TX 15, TX 20, TX 25, TX 27, TX 30, TX 40), 188.1/1ABI (1/4"), 188.3/2 (1/4"), 188.4/2 (1/4" x 150, 1/4" x 55), 188.6/2 (1/4"), 188.8 (1/4"), 190/1 6p (10, 11, 12, 13, 14, 15, 16, 17, 18, 19, 20, 21, 22, 23, 24, 26, 27, 28, 30, 32), 190.1/1ABI (1/2"), 190.3/1 (1/2"), 190.4/1S (1/2" x 125, 1/2" x 250), 190.6/2 (1/2"), VL964/47SOS (564 x 364 x 30)

#### 964/48SOS (623989)



447/1HPP (240), 466/1BI (180), 508/1BI (170), 405/1BI (180), 532PLUS/1DP (180 x 19 - 60), 534PLUS/4DP (180 x 19 - 60), 536PLUS/1DP (180 x 19 - 60), 538PLUS/4DP (180 x 19 - 60), 430/3 (250), 582/3P (150), 812 (400), 820A (32), 819A (45), VL964/48SOS (564 x 364 x 30)

# 1011BEV4 (621757)

## Tool set 193 pcs with tool carriage 940EV4



static load capacity of carriage without wheels: 1600kg

Basic tool set for maintenance in car repair workshops, agro services and maintenance in the industry.

### 940EV4 Tool carriage Eurovision

- Opening and closing of drawers is very simple due to the uniform solution - drawer handle on the upper side enables users a synchronic grip and opening of a carriage drawer.
- Drawer closing mechanism prevents unwanted opening of drawers.
- Possibility to add accessories.
- 7 drawers (five dimensions 563x365x70mm, two dimensions 563x410x150mm).

maximum capacity of each drawer: 40kg



drawers with ball-bearing slides



locking system

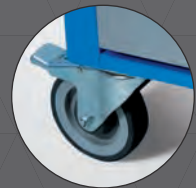

new wheels dia. 125mm, for improved agility and stability

#### 964/37SOS (621396)



605TBI (0.5 x 3.0 x 80, 0.8 x 4.0 x 100, 1.0 x 5.5 x 125, 1.2 x 6.5 x 150, 1.6 x 8.0 x 175), 615TBI (PH 0 x 60, PH 1 x 80, PH 2 x 100, PH 3 x 150), 626TBI (PH 1 x 25, PH 2 x 25), 627TBI (1.0 x 5.5 x 25, 1.2 x 6.5 x 25), 621TBI (TX 6, TX 8, TX 10, TX 15, TX 20, TX 25, TX 27, TX 30, TX 40), 193HXS (3, 4, 5, 6, 8, 10), v1964/37SOS (564 x 364 x 30)

#### 964/32ASOS (623936)



406/1BI (180), 430/3 (250), 447/1HPP (240), 466/1BI (180), 514/1BI (160), 512/1BI (200), 532PLUS/1DP (180 x 19 - 60), 534PLUS/1DP (180 x 19 - 60), 536PLUS/1DP (180 x 19 - 60), 538PLUS/1DP (180 x 19 - 60), 642/6 (5), 660/6 (200), 812 (400), 820A (40), v1964/32ASOS (564 x 364 x 30)

#### 964/35SOS (621394)

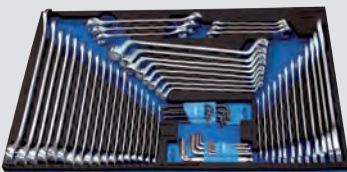

110/1 (6 x 7, 8 x 9, 10 x 11, 12 x 13, 14 x 15, 16 x 17, 18 x 19, 20 x 22, 21 x 23, 24 x 27, 25 x 28, 30 x 32), 120/1 (6, 7, 8, 9, 10, 11, 12, 13, 14, 15, 16, 17, 18, 19, 20, 21, 22, 24, 27), 180/1 (6 x 7, 8 x 9, 10 x 11, 12 x 13, 14 x 15, 16 x 17, 18 x 19, 20 x 22), 183/2 (8 x 10, 10 x 11, 11 x 13, 12 x 14, 17 x 19, 19 x 22), 220/35 (1.5, 2, 2.5, 3, 4, 5, 6, 8, 10), 220/7TX (TR 9, TR 10, TR 15, TR 20, TR 25, TR 27, TR 30, TR 40), v1964/35SOS (564 x 364 x 30)

#### 964/36SOS (621395)

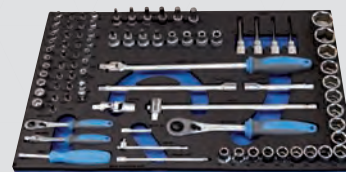

188/2 6p (4, 4.5, 5, 5.5, 6, 7, 8, 9, 10, 11, 12, 13), 189/2 (E 4, E 5, E 6, E 7, E 8, E 10, E 11), 187/2HX (3, 4, 5, 6, 7), 187/2TX (TX 8, TX 10, TX 15, TX 20, TX 25, TX 27, TX 30, TX 40), 187/2SL (0.8 x 4, 1 x 5.5, 1.2 x 7), 187/2PH (PH 1, PH 2, PH 3), 188.1/1ABI (1/4"), 188.2/2BI (1/4"), 188.3/2 (1/4"), 188.4/2 (1/4" x 55, 1/4" x 150), 188.6/2 (1/4"), 188.7/2 (1/4" - 3/8"), 188.8 (1/4"), 190/1 6p (10, 11, 12, 13, 14, 15, 16, 17, 18, 19, 20, 21, 22, 23, 24, 27, 30, 32), 191/1 (E 10, E 11, E 12, E 14), 192/2HX (6, 7, 8, 9, 10, 12), 192/2TX (TX 30, TX 40, TX 45, TX 50), 192/2ZXL (M 6, M 8, M 10, M 12), 190.1/1ABI (1/2"), 190.2/1BI (1/2" x 380), 190.3/1 (1/2"), 190.4/1 (1/2" x 250, 1/2" x 125), 190.6/2 (1/2"), v1964/36SOS (564 x 364 x 30)

# 1011DEV6 (624138)

## Tool set 238 pcs with tool carriage 940EV6

static load capacity of carriage without wheels: 1600kg



Basic tool set for maintenance in car repair workshops, agro services and maintenance in the industry.

### 940EV6 Tool carriage Eurovision

- opening and closing of drawers is very simple due to the uniform solution - drawer handle on the upper side enables users a synchronic grip and opening of a carriage drawer.
- Drawer closing mechanism prevents unwanted opening of drawers.
- possibility to add accessories
- 8 drawers (seven dimensions 563x365x70mm, one dimension 563x410x150mm)

maximum capacity of each drawer: 40kg



drawers with ball-bearing slides



locking system

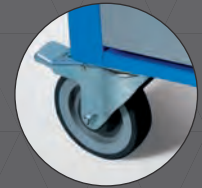

new wheels dia. 125mm, for improved agility and stability

#### 964/28SOS (621387)

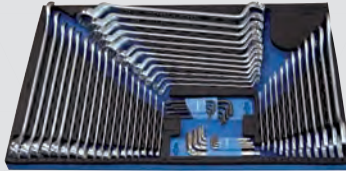

110/1 (6 x 7, 8 x 9, 10 x 11, 12 x 13, 14 x 15, 16 x 17, 18 x 19, 20 x 22, 21 x 23, 24 x 27, 25 x 28, 30 x 32), 120/1 (6, 7, 8, 9, 10, 11, 13, 14, 15, 16, 17, 18, 19, 20, 21, 22, 24, 27), 180/1 (6 x 7, 8 x 9, 10 x 11, 12 x 13, 14 x 15, 16 x 17, 18 x 19, 20 x 22, 21 x 23, 24 x 26, 25 x 28, 27 x 32), 220/35 (1.5, 2, 2.5, 3, 4, 5, 6, 8, 10), 220/7TX (TR 9, TR 10, TR 15, TR 20, TR 25, TR 27, TR 30, TR 40), VL964/28SOS (564 x 364 x 30)

#### 964/33SOS (621392)



605TBI (0.5 x 3.0 x 80, 0.8 x 4.0 x 100, 1.0 x 5.5 x 125, 1.2 x 6.5 x 150, 1.6 x 8.0 x 175), 615TBI (PH 0 x 60, PH 1 x 80, PH 2 x 100, PH 3 x 150), 626TBI (PH 1 x 25, PH 2 x 25), 627TBI (1.0 x 5.5 x 25, 1.2 x 6.5 x 25), 621TBI (TX 6, TX 8, TX 10, TX 15, TX 20, TX 25, TX 27, TX 30, TX 40), 629TBI (6, 7, 8, 9, 10, 11, 12, 13), VL964/33SOS (564 x 364 x 30)

#### 964/29ASOS (623932)



215/2 (6 x 7, 8 x 10, 13 x 17, 19 x 22, 24 x 27, 30 x 32), 215.1/2 (6 - 17, 18 - 41), 182/2BTX (6 x 8, 10 x 12, 14 x 18, 20 x 24), 183/2 (8 x 10, 10 x 11, 11 x 13, 12 x 14, 16 x 18, 17 x 19, 19 x 22, 22 x 24, 24 x 27, 30 x 32), 202/1 (8 x 9, 10 x 11, 12 x 13, 14 x 15, 16 x 17, 18 x 19), VL964/29ASOS (564 x 364 x 30)

#### 964/48SOS (623989)



447/1HPP (240), 466/1BI (180), 508/1BI (170), 405/1BI (180), 532PLUS/1DP (180 x 19 - 60), 534PLUS/4DP (180 x 19 - 60), 536PLUS/1DP (180 x 19 - 60), 538PLUS/4DP (180 x 19 - 60), 430/3 (250), 582/3P (150), 812 (400), 820A (32), 819A (45), VL964/48SOS (564 x 364 x 30)

#### 964/30SOS (621389)



188/2 6p (4, 4.5, 5, 5.5, 6, 7, 8, 9, 10, 11, 12, 13), 189/2 (E 4, E 5, E 6, E 7, E 8, E 10, E 11), 187/2HX (3, 4, 5, 6, 7), 187/2TX (TX 8, TX 10, TX 15, TX 20, TX 25, TX 27, TX 30, TX 40), 187/2SL (0.8 x 4, 1 x 5.5, 1.2 x 7), 187/2PH (PH 1, PH 2, PH 3), 188.1/1ABI (1/4"), 188.2/2BI (1/4"), 188.3/2 (1/4"), 188.4/2 (1/4" x 55, 1/4" x 150), 188.6/2 (1/4"), 188.7/2 (1/4" - 3/8"), 188.8 (1/4"), 238/1 6p (6, 7, 8, 9, 10, 11, 12, 13, 14, 15, 16, 17, 18, 19, 20, 21, 22), 238.1/1FBI (3/8"), 238.2/1BI (3/8"), 238.3/1 (3/8"), 238.4/2 (3/8" x 45, 3/8" x 75), 238.4/1 (3/8" x 125, 3/8" x 250), 238.6/1 (3/8"), 238.7/2 (3/8" - 1/2"), 190/1 6p (10, 11, 12, 13, 14, 15, 16, 17, 18, 19, 20, 21, 22, 23, 24, 27, 30, 32), 190.1/1ABI (1/2"), 190.2/1BI (1/2" x 380), 190.3/1 (1/2"), 190.4/1 (1/2" x 250, 1/2" x 125), 190.6/2 (1/2"), VL964/30SOS (564 x 364 x 30)

#### 964/49SOS (623990)



660/6 (150, 200), 642/6 (5), 641/6 (3, 4, 5, 6), 300/5C (320), 701 (0.05 - 1 x 20), 753P (150), 556A (160), 710P (3), 2087 (1), 2035 (1), 760H1/25 (200), 764H1/25 (200), 763H1/25 (200), 761H1/25 (200), VL964/49SOS (564 x 364 x 30)



# 1011AEV6 (621756)

## Tool set 325 pcs with tool carriage 940EV6



static load capacity of carriage without wheels: 1600kg

Basic tool set for maintenance in car repair workshops, agro services and maintenance in the industry.

### 940EV6 Tool carriage Eurovision

- Opening and closing of drawers is very simple due to the uniform solution - drawer handle on the upper side enables users a synchronic grip and opening of a carriage drawer.
- Drawer closing mechanism prevents unwanted opening of drawers.
- Possibility to add accessories.
- 8 drawers (seven dimensions 563x365x70mm, one dimension 563x410x150mm).

maximum capacity of each drawer: 40kg



drawers with ball-bearing slides



locking system

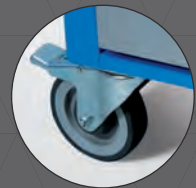

new wheels dia. 125mm, for improved agility and stability

#### 964/31SOS (621390)



□ 192/2TX (TX 20, TX 25, TX 27, TX 30, TX 40, TX 45, TX 50, TX 55, TX 60), □ 192/2TXL (TX 20, TX 25, TX 27, TX 30, TX 40, TX 45, TX 50, TX 55, TX 60), □ 191/1 (E 10, E 11, E 12, E 14, E 16, E 18, E 20, E 22, E 24), □ 192/2ZX (M 5, M 6, M 8, M 10, M 12, M 14), □ 192/2ZXL (M 6, M 8, M 10, M 12, M 14), □ 192/2HX (5, 6, 7, 8, 9, 10, 12, 14), □ 192/2HXL (5 x 100, 6 x 100, 7 x 100, 8 x 100, 10 x 100, 12 x 100), □ 190/1 12p (10, 11, 12, 13, 14, 15, 16, 17, 18, 19, 20, 21, 22, 24, 27, 30, 32), □ 186.4/2 (21, 19, 16), □ 641/6 (2, 3, 4, 5, 6, 8), □ 263A (30 - 150), v1964/31SOS (564 x 364 x 30)

#### 964/28SOS (621387)



⌚ 110/1 (6 x 7, 8 x 9, 10 x 11, 12 x 13, 14 x 15, 16 x 17, 18 x 19, 20 x 22, 21 x 23, 24 x 27, 25 x 28, 30 x 32), ⌚ 120/1 (6, 7, 8, 9, 10, 11, 13, 14, 15, 16, 17, 18, 19, 20, 21, 22, 24, 27), ⌚ 180/1 (6 x 7, 8 x 9, 10 x 11, 12 x 13, 14 x 15, 16 x 17, 18 x 19, 20 x 22, 21 x 23, 24 x 26, 25 x 28, 27 x 32), □ 220/3S (1.5, 2, 2.5, 3, 4, 5, 6, 8, 10), □ 220/7TX (TR 9, TR 10, TR 15, TR 20, TR 25, TR 27, TR 30, TR 40), v1964/28SOS (564 x 364 x 30)

#### 964/32ASOS (623936)



⌘ 406/1BI (180), ⌘ 430/3 (250), ⌘ 447/1HPP (240), ⌘ 466/1BI (180), ⌘ 514/1BI (160), ⌘ 512/1BI (200), ⌘ 532PLUS/1DP (180 x 19 - 60), ⌘ 534PLUS/1DP (180 x 19 - 60), ⌘ 536PLUS/1DP (180 x 19 - 60), ⌘ 538PLUS/1DP (180 x 19 - 60), ⌘ 642/6 (5), ⌘ 660/6 (200), ⌘ 812 (400), ⌘ 820A (40), v1964/32ASOS (564 x 364 x 30)

#### 964/29ASOS (623932)



□ 215/2 (6 x 7, 8 x 10, 13 x 17, 19 x 22, 24 x 27, 30 x 32), □ 215.1/2 (6 - 17, 18 - 41), ⌚ 182/2BTX (6 x 8, 10 x 12, 14 x 18, 20 x 24), ⌚ 183/2 (8 x 10, 10 x 11, 11 x 13, 12 x 14, 16 x 18, 17 x 19, 19 x 22, 22 x 24, 24 x 27, 30 x 32), □ 202/1 (8 x 9, 10 x 11, 12 x 13, 14 x 15, 16 x 17, 18 x 19), v1964/29ASOS (564 x 364 x 30)

#### 964/33SOS (621392)



⌘ 605TBI (0.5 x 3.0 x 80, 0.8 x 4.0 x 100, 1.0 x 5.5 x 125, 1.2 x 6.5 x 150, 1.6 x 8.0 x 175), ⌘ 615TBI (PH 0 x 60, PH 1 x 80, PH 2 x 100, PH 3 x 150), ⌘ 626TBI (PH 1 x 25, PH 2 x 25), ⌘ 627TBI (1.0 x 5.5 x 25, 1.2 x 6.5 x 25), ⌘ 621TBI (TX 6, TX 8, TX 10, TX 15, TX 20, TX 25, TX 27, TX 30, TX 40), ⌘ 629TBI (6, 7, 8, 9, 10, 11, 12, 13), v1964/33SOS (564 x 364 x 30)

#### 964/30SOS (621389)



□ 188.2/6p (4, 4.5, 5, 5.5, 6, 7, 8, 9, 10, 11, 12, 13), □ 189/2 (E 4, E 5, E 6, E 7, E 8, E 10, E 11), □ 187/2HX (3, 4, 5, 6, 7), □ 187/2TX (TX 8, TX 10, TX 15, TX 20, TX 25, TX 27, TX 30, TX 40), □ 187/2SL (0.8 x 4, 1 x 5.5, 1.2 x 7), □ 187/2PH (PH 1, PH 2, PH 3), □ 188.1/1ABI (1/4"), □ 188.2/2BI (1/4"), □ 188.3/2 (1/4"), □ 188.4/2 (1/4" x 55, 1/4" x 150), □ 188.6/2 (1/4"), □ 188.7/2 (1/4" - 3/8"), □ 188.8 (1/4"), □ 238/1 6p (6, 7, 8, 9, 10, 11, 12, 13, 14, 15, 16, 17, 18, 19, 20, 21, 22), □ 238.1/1FBI (3/8"), □ 238.2/1BI (3/8"), □ 238.3/1 (3/8"), □ 238.4/2 (3/8" x 45, 3/8" x 75), □ 238.4/1 (3/8" x 125, 3/8" x 250), □ 238.6/1 (3/8"), □ 238.7/2 (3/8" - 1/2"), □ 190/1 6p (10, 11, 12, 13, 14, 15, 16, 17, 18, 19, 20, 21, 22, 23, 24, 27, 30, 32), □ 190.1/1ABI (1/2"), □ 190.2/1BI (1/2" x 380), □ 190.3/1 (1/2"), □ 190.4/1 (1/2" x 250, 1/2" x 125), □ 190.6/2 (1/2"), v1964/30SOS (564 x 364 x 30)

#### 964/34SOS (621393)



⌘ 193HXS (2.5, 3, 4, 5, 6, 8, 10), ⌘ 193TX (TX 10, TX 15, TX 20, TX 25, TX 27, TX 30, TX 40, TX 45), ⌘ 760H1/2S (200), ⌘ 764H1/2S (200), ⌘ 556B (160), v1964/34SOS (564 x 364 x 30)

## Torque wrenches

Unior offers a broad range of professional torque products. Our torque product line ranges from dial torque wrenches, slipper torque wrenches, torque wrenches and industrial torque wrenches. Each torque wrench is manufactured to precise specifications for maximum performance for your torque application.

Each Unior torque wrench includes Calibration Certificate that verifies the actual readings. Unior torque wrenches are certified to meet, and exceed the standards specified in ISO 6789.

## What is torque wrench?

A torque wrench is a wrench used to precisely set the torque of a fastener such as a nut or bolt. It is usually in the form of a socket wrench with special internal mechanisms. A torque wrench is used where the tightness of screws and bolts is crucial. It allows the operator to measure the torque applied to the bolt so it can be matched to the specifications.

This permits proper tension and loading of all parts. A torque wrench indirectly measures bolt tension. The technique suffers from inaccuracy due to inconsistent friction between the fastener and its mating hole. Measuring bolt tension (bolt stretch) is more accurate but most often torque is the only means of measurement possible.

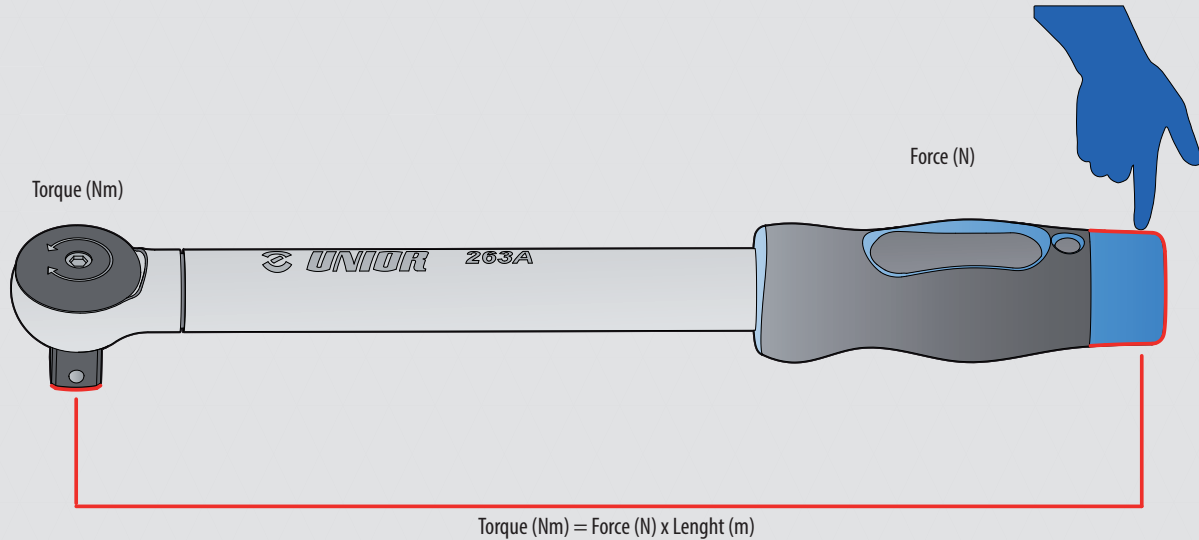

### 263A

#### Slipper torque wrench 1/2"

- accuracy: +/-3%
- micrometer scale for simple and error free settings
- adjustment lock to set torque
- torque application: bothway, but always apply in direction specified on torque wrench handle
- handle: Two component material
- dual scale lbf.ft and Nm

#### Important!

- Do not use torque wrench for untightening!
- Torque tightens only in the direction showed on the key sticker! Sticker shows the proper direction of tightening!
- The default calibration interval of the torque wrench is 12 months or 5.000 measurements from the date of end user purchase.
- ALWAYS set the measuring mechanism to starting point, at the end of work.
- When the requested torque is reached, please do not tight any more.
- Torque wrench can be damaged, if manual instructions are not considered.

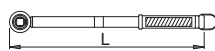

Barcode	Min	Max	L	Size	Weight	IS	QTY
620110	30 - 150	20 - 110	455	1/2"	1300	IS	1
620111	50 - 250	40 - 185	560	1/2"	1645	IS	1

### 263B

#### Slipper torque wrench 1/2"

- accuracy: +/-3%
- micrometer scale for simple and error free settings
- adjustment lock to set torque
- torque application: oneway, but always apply in direction specified on torque wrench handle
- ratchet: works both ways, 75teeth and 5° increments
- handle: Two component material
- dual scale lbf.ft and Nm

#### Important!

- Do not use torque wrench for untightening!
- Torque tightens only in the direction showed on the key sticker! Sticker shows the proper direction of tightening!
- The default calibration interval of the torque wrench is 12 months or 5.000 measurements from the date of end user purchase.
- ALWAYS set the measuring mechanism to starting point, at the end of work.
- When the requested torque is reached, please do not tight any more.
- Torque wrench can be damaged, if manual instructions are not considered.

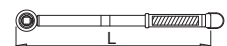

Barcode	Min	Max	L	Size	Weight	IS	QTY
620109	8 - 50	8 - 35	280	1/2"	615	IS	1

1. Unscrew the bottom bolt, to release screw for torque adjustment.
2. Adjust to designated torque.
3. Screw back bottom bolt, to fix torque adjustment.
4. Adjust and start tightening (prescribed torque direction). When you hear audio signal (click), the designated torque is reached. Stop tightening.

### 264 Slipper torque wrench

- reversible ratchet head
- torque application: oneway, but always apply in direction specified on torque wrench handle
- ratchet operates in clockwise and anti-clockwise directions
- for tightening on left and right hand threads
- unmistakable signal when set torque is reached
- Default value for the recalibration interval is 12 month of use, or approximately 5.000 cycles!
- made according to standard ISO 6789
- dual scaled, Nm and Kgm

**Important!**

- Do not use torque wrench for untightening!
- Torque tightens only in the direction showed on the key sticker! Sticker shows the proper direction of tightening!
- The default calibration interval of the torque wrench is 12 months or 5.000 measurements from the date of end user purchase.
- ALWAYS set the measuring mechanism to starting point, at the end of work.
- When the requested torque is reached, please do not tight any more.
- Torque wrench can be damaged, if manual instructions are not considered.

Barcode	Color	Scale	L	Weight	Material	IS	Qty
615485	1/4"	2 - 24	270	686	15	1	
615486	3/8"	5 - 110	360	1100	15	1	
615487	1/2"	28 - 210	465	1680	15	1	
615488	1/2"	35 - 350	640	2930	15	1	
615489	3/4"	70 - 560	840	5600	15	1	
615490	3/4"	140 - 700	1070	8200	15	1	
615491	1"	140 - 980	1220	8800	15	1	

### 263L Slipper torque wrench 1/2"

- double ended ratcheting spindles
- torque application: bothway, but always apply in direction specified on torque wrench handle
- with overload protection
- visual signal by pointer, when set torque is reached
- supplied in durable storage case
- dual scale lbf.ft and Nm
- Default value for the recalibration interval is 12 month of use, or approximately 5.000 cycles!
- made according to standard ISO 6789

**Important!**

- Do not use torque wrench for untightening!
- Torque tightens only in the direction showed on the key sticker! Sticker shows the proper direction of tightening!
- The default calibration interval of the torque wrench is 12 months or 5.000 measurements from the date of end user purchase.
- ALWAYS set the measuring mechanism to starting point, at the end of work.
- When the requested torque is reached, please do not tight any more.
- Torque wrench can be damaged, if manual instructions are not considered.

Barcode	Scale	Scale	L	Weight	Material	IS	Qty
607948	60 - 330	45 - 250	675	1710	15	1	

### 267A Pre-set torque wrenches for cars

- material: chrome vanadium
- guaranteed to meet ISO 6789, ANSI 107.14M and U.S. Fed GGG-W-686D
- torque is preset
- easy to use and calibrate
- factory calibrated for accuracy to within +/-4%

**Important!**

- Do not use torque wrench for untightening!
- Torque tightens only in the direction showed on the key sticker! Sticker shows the proper direction of tightening!
- The default calibration interval of the torque wrench is 12 months or 5.000 measurements from the date of end user purchase.
- When the requested torque is reached, please do not tight any more.
- Torque wrench can be damaged, if manual instructions are not considered.

Barcode	Scale	Scale	Color	L	Weight	Material	IS	Qty
618915	90	66.4	black	400	1340	15	1	
618916	100	73.7	yellow	400	1335	15	1	
618917	110	81.1	gray	400	1335	15	1	
618918	120	88.5	red	400	1335	15	1	
618919	130	95.9	blue	400	1335	15	1	

267B

Pre-set torque wrenches for trucks

- material: chrome vanadium
- guaranteed to meet ISO 6789, ANSI 107.14M and U.S. Fed GGG-W-686D
- torque is preset
- easy to use and calibrate
- factory calibrated for accuracy to within +/-4%



Important!

- Do not use torque wrench for untightening!
- Torque tightens only in the direction showed on the key sticker! Sticker shows the proper direction of tightening!
- The default calibration interval of the torque wrench is 12 months or 5.000 measurements from the date of end user purchase.
- When the requested torque is reached, please do not tight any more.
- Torque wrench can be damaged, if manual instructions are not considered.

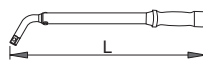

Barcode	Color	L	Weight	Capacity	Material	Scale	Unit
618920	400 295 green	950	4650	TS	1	⊙	
618921	450 332 purple	950	4650	TS	1	⊙	
618922	500 369 khaki/sand	950	4680	TS	1	⊙	
618923	550 406 light blue	950	4665	TS	1	⊙	
618924	600 442 orange	950	4670	TS	1	⊙	



265

Industrial torque wrench 3/4"



- robust construction gives accurate results, to +/-4%, even in arduous working conditions
- every wrench is supplied with a calibration certificate according to ISO 9000:2000
- the large break angle improves accuracy by reducing the possibility of over torquing
- cam control of the mechanism gives a controlled break which will not throw the operator off balance
- torque application: bothway, but always apply in direction specified on torque wrench handle
- dual scaled, N.m and lbf.ft
- made according to standard ISO 6789

Usage

- agricultural equipment
- building sector
- heavy industry
- larger construction machinery
- shipbuilding industry
- aircraft industry
- Do not use torque wrench for untightening!

Important!

- Tool must be used with equal pulls and in accordance with the instructions in the manual.
- Torque tightens only in the direction showed on the key sticker! Sticker shows the proper direction of tightening!
- The default calibration interval of the torque wrench is 12 months or 5.000 measurements from the date of end user purchase.
- ALWAYS set the measuring mechanism to starting point, at the end of work.
- When the requested torque is reached, please do not tight any more.
- Torque wrench can be damaged, if manual instructions are not considered.

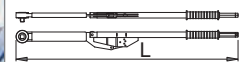
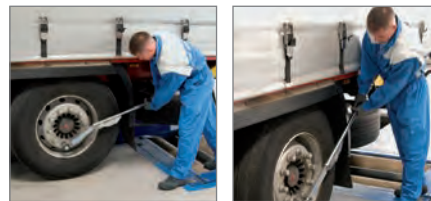

Barcode	Size	Capacity	Weight	Material	Scale	Unit
616801	3/4" 150 - 700	100 - 500	1090	8500	TS	1
616802	3/4" 200 - 800	150 - 600	1140	9000	TS	1
616803	3/4" 300 - 1000	200 - 750	1470	11000	TS	1

270A

Digital vernier

- accuracy: 0,02mm/0,001"
- measuring speed: 1.5m/sec
- function: measurement of internal dimensions, of external dimensions, of depth, of steps
- made according to standard DIN 862
- dual scale in inch and mm

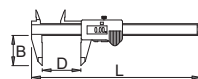

Barcode	D	B	L	Weight	Material	Unit
619881	0 - 150	40	235	460	TF	1

271

Vernier

- accuracy: 0,02mm/0,001"
- function: measurement of internal dimensions, of external dimensions, of depth, of steps
- made according to standard DIN 862
- dual scale in inch and mm

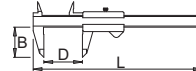

Barcode	D	B	L	Weight	Material	Unit
612035	0 - 150	40	235	240	TF	1

272

External micrometer

- made of quality casting. Measuring surface made of hardened alloy
- spindle 6,5mm dia., with locking lever and ratchet
- according to DIN 863
- measuring range 0 - 25mm, minimal reading 0,01mm
- made according to standard DIN 863



Barcode	Weight	Material	Unit
617698	300	TF	1

**Torque multiplier**

- 5:1 torque multiplication, accuracy guaranteed better than +/-4%
- supplied with two reaction bar styles for maximum versatility
- robust construction means minimal maintenance and long life
- Supplied in a carrying case. Ideal for inclusion in the heavy vehicle tool kit.



**Advantages:**

- Exactly defined multiplication – no need of tabular conversions
- Simple use does not require any additional knowledge

**Usage**

- building construction
- agricultural equipment
- heavy industry
- larger construction machinery
- shipbuilding industry
- aircraft industry
- train compositions
- refineries

**Important!**

- The use of Unior IMPACT sockets is recommended.
- We shall never exceed the requested torque starting point of the multiplier.

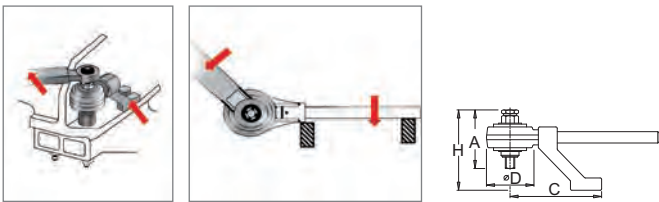

Barcode	mm	mm	Ratio	Socket Size	Reaction Bar Size	Weight (kg)	Length (mm)	Length (in)	Length (ft)	Weight (lb)	Case	Accessories
616804	1300	960	5:1	1/2"(32mm)	3/4"	108	126	210	180	7000	1F	1
616805	2700	2000	5:1	3/4"(36mm)	1"	108	128	210	186	7000	1F	1



**710R**

**Measuring tape**

- plastic double component casing
- with stop and clip



Barcode	m	ft	d	Weight (kg)	Case	Accessories
612789	2	0	16	95	4A	10
612790	3	0	16	140	4A	10
612791	5	0	19	230	4A	10
612792	8	0	25	370	4A	10
612793	2	6	16	96	4A	10
612794	3	10	16	110	4A	10
612795	5	16	19	230	4A	10
612796	8	26	25	370	4A	10

**710P**

**Measuring tape**

- plastic double component casing
- with stop and clip



Barcode	m	ft	d	Weight (kg)	Case	Accessories
612131	2	0	16	113	4A	10
612132	3	0	16	140	4A	10
612133	5	0	19	230	4A	10
612134	8	0	25	441	4A	10
612135	10	0	25	470	4A	10
612784	2	6	16	111	4A	10
612785	3	10	16	140	4A	10
612786	5	16	19	225	4A	10
612787	8	26	25	431	4A	10
612788	10	33	25	474	4A	10

**714**

**Long measuring tape**

- plastic double component casing
- acrylic coated steel tape enable long life
- 6 times speed of tape rewind against handle turns

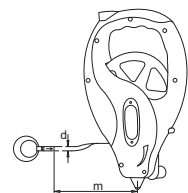

Barcode	m	d	Weight (kg)	Case	Accessories
621525	50	13	1100	1G	1

# How to connect Unior Pneumatic tools?



maximum air pressure : 9,5 Bar

Alternative connection between article 1508A and 1508B when working on the cleanest surfaces (for example the dashboard of a car)

<b>1500</b> <span style="float: right;">1/4"</span>  617735	<b>1501</b> <span style="float: right;">3/8"</span>  617736	<b>1502</b> <span style="float: right;">1/2"</span>  617737	<b>1503</b> <span style="float: right;">3/4"</span>  621473
---	---	---	---

<b>1506KZ7</b> <span style="float: right;">1/4"</span>  617793	<b>1506KZ7, 1506KZ10</b> <span style="float: right;">3/8"</span>  617794	<b>1506KZ10</b> <span style="float: right;">1/2"</span>  621453	<b>1506KZ10</b> <span style="float: right;">3/4"</span>  621454
--	--	---	---

<b>1507Z7</b> <span style="float: right;">1/4"</span>  617797	<b>1507Z7</b> <span style="float: right;">1/4"</span>  617797	<b>1507Z10</b> <span style="float: right;">3/8"</span>  621455
---	---	--

## How to fasten with the right wrench?

Article	Part Number	Size	Length
1506KN7	617795	1/4"	20
1506KN7	617796	3/8"	20
1506KZ7	617793	1/4"	20
1506KZ7	617794	3/8"	20
1506KZ10	621452	3/8"	24
1506KZ10	621453	1/2"	24
1506KZ10	621454	3/4"	27
1507Z7	617797	1/4"	14
1507Z7	617798	3/8"	19
1507Z7	618483	1/2"	22
1507Z10	621455	3/8"	17
1507Z10	621456	1/2"	24
1507Z10	621457	3/4"	27

<b>1505</b> <span style="float: right;">1/4"</span>  617743, 617746	<b>1505</b> <span style="float: right;">1/4"</span>  617744, 617747	<b>1505</b> <span style="float: right;">3/8"</span>  617745, 617748
---	---	---

<b>1506KZ7</b> <span style="float: right;">1/4"</span>  617793	<b>1506KZ7</b> <span style="float: right;">1/4"</span>  617793	<b>1506KZ7</b> <span style="float: right;">3/8"</span>  617794	<b>1506KZ10</b> <span style="float: right;">3/8"</span>  621452
--	--	--	---

<b>1507Z7</b> <span style="float: right;">1/4"</span>  617797	<b>1507Z7</b> <span style="float: right;">1/4"</span>  617797	<b>1507Z10</b> <span style="float: right;">3/8"</span>  621455	<b>1507Z10</b> <span style="float: right;">1/2"</span>  621456
---	---	--	--

- 1508A (617767)
- 1508B (617768)
- 1514 (615320)
- 1531 (615318)

- 1517 P (617728)
- 1517 S (617729)
- 1541 (615320)
- 1561 (615322)
- 1551 (615319)
- 1562 (615321)
- 1571 (615324)
- 1510 (617733, 617713)
- 1514 (617714, 617715)

- 1515 (617726)
- 1515 H (617727)
- 1516 (617731)
- 1516 A (617732)
- 1531 (615318)
- 1518 (617730)

- 1572 (615323)

- 1591 (615325)
- 1592 (615326)
- 1596 (617690)
- 1597 (617691)

1531

**Pneumatic reversible ratchet 3/8"**

- free speed 250 revolution per minutes
- max. torque 54 Nm
- maximum air pressure : 6,2 Bar
- air consumption 71 l/min
- air inlet 1/4"
- max bolt size M6

**Advantages:**

- small and compact tool
- quality production
- handy turn-on switch
- fast and handy adjustment of the rotation direction
- sluice-gate enabling prevention of air inlet into the tool

**Usage**

- car industry
- aircraft industry
- agricultural equipment
- heavy industry
- larger construction machinery
- shipbuilding industry
- individual mounting

**Important!**

- The use of Unior IMPACT sockets is recommended.

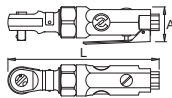

615318 3/8" 37 165 54 520 1F 1

1541

**Pneumatic reversible hammer 3/8"**

- free speed 10000 revolution per minutes
- max. torque 271 Nm
- maximum air pressure : 6,2 Bar
- air consumption 71 l/min
- air inlet 1/4"
- max bolt size M10

**Advantages:**

- controlled torque
- fast screwing
- wide range of use

**Usage**

- car industry
- aircraft industry
- agricultural equipment
- heavy industry
- larger construction machinery
- shipbuilding industry
- individual mounting

**Important!**

- Always use Unior IMPACT sockets.

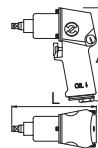

615320 3/8" 175 139 271 1350 1F 1

1551

**Pneumatic reversible ratchet 1/2"**

- free speed 160 revolution per minutes
- max. torque 81 Nm
- maximum air pressure : 6,2 Bar
- air consumption 113 l/min
- air inlet 1/4"
- max bolt size M10

**Advantages:**

- small and compact tool
- quality production
- handy turn-on switch
- fast and handy adjustment of the rotation direction
- sluice-gate enabling prevention of air inlet into the tool

**Usage**

- car industry
- aircraft industry
- agricultural equipment
- heavy industry
- larger construction machinery
- shipbuilding industry
- individual mounting

**Important!**

- The use of Unior IMPACT sockets is recommended.

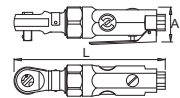

615319 1/2" 45 254 81 1370 1F 1

1535

**Pneumatic ratchet and socket set 3/8" in plastic box**

- Dimension of box: 244 x 207 x 44



615513 8-17/13 2450 1G 1

☞ 1531 (3/8"), ☞ 230.4/4 (3/8"x125, 3/8"x75), ☞ 230.8/4 (6-12, 13-21), ☞ 230/4 6p (8, 10, 11, 12, 13, 15, 17), 1374 (50ml)



1545

**Pneumatic hammer and socket set 3/8" in plastic box**

- Dimension of box: 307 x 260 x 70



615514 8-17/14 2515 1G 1

☞ 1541 (3/8"), ☞ 230.4/4 (3/8"x125, 3/8"x75), ☞ 230.8/4 (6-12, 13-21), ☞ 230/4 6p (8, 10, 11, 12, 13, 14, 15, 17), 1374 (50ml)

1555

**Pneumatic ratchet and socket set 1/2" in plastic box**

- Dimension of box: 307 x 260 x 70



615515 10-24/14 3145 1G 1

☞ 1551 (1/2"), ☞ 231.4/4 (1/2"x125, 1/2"x75), ☞ 231.8/4 (10-14, 15-32), ☞ 231/4 6p (10, 13, 14, 17, 19, 21, 22, 24), 1374 (50ml)

**1561**

**Pneumatic reversible hammer 1/2"**

- free speed 8000 revolution per minutes
- max. torque 814 Nm
- maximum air pressure : 6,2 Bar
- air consumption 113 l/min
- air inlet 1/4"
- max bolt size M16

**Advantages:**

- controlled torque
- fast screwing
- wide range of use

**Usage**

- car industry
- aircraft industry
- agricultural equipment
- heavy industry
- larger construction machinery
- shipbuilding industry
- individual mounting

**Important!**

- Always use Unior IMPACT sockets.

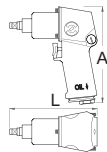

615322 1/2" 190 188 814 2910 TF 1

**1562**

**Pneumatic reversible hammer 1/2"**

- free speed 7000 revolution per minutes
- max. torque 949 Nm
- maximum air pressure : 6,2 Bar
- air consumption 119 l/min
- air inlet 1/4"
- max bolt size M18

**Advantages:**

- controlled torque
- fast screwing
- wide range of use

**Usage**

- car industry
- aircraft industry
- agricultural equipment
- heavy industry
- larger construction machinery
- shipbuilding industry
- individual mounting

**Important!**

- Always use Unior IMPACT sockets.

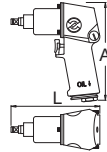

615321 1/2" 192 204 949 2800 TF 1

**1571**

**Pneumatic reversible hammer 3/4"**

- free speed 6500 revolution per minutes
- max. torque 1085 Nm
- maximum air pressure : 6,2 Bar
- air consumption 198 l/min
- air inlet 1/4"
- max bolt size M24

**Advantages:**

- controlled torque
- fast screwing
- wide range of use

**Usage**

- car industry
- aircraft industry
- agricultural equipment
- heavy industry
- larger construction machinery
- shipbuilding industry
- individual mounting

**Important!**

- Always use Unior IMPACT sockets.

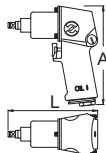

615324 3/4" 240 236 1085 4550 TF 1

**1565**

**Pneumatic hammer and socket set 1/2" in plastic box**

- Dimension of box: 346 x 292 x 83



615516 10 - 27 / 20 5600 IG 1

- ◀ 1561 (1/2"), □ 231.4/4 (1/2" x 125, 1/2"x75), ◎ 231.8/4 (10 - 14, 15 - 32), □ 231/4 6p (10, 13, 17, 19, 21, 22, 24, 27), 1374 (50ml), 231/4L6p (17, 19, 21, 22, 24, 27)



**1575**

**Pneumatic hammer and socket set 3/4" in plastic box**

- Dimension of box: 393 x 331 x 95



617161 7 8330 IG 1

- ◀ 1571 (3/4"), □ 232/4 6p (19, 24, 27, 32, 36, 41)



# FAULTLESS INSTALLATION OF TYRES

## Why do you need a special tool for installing tyres?

Because the bolts must be tightened using a precisely determined force.

Changing car tyres in a car workshop should not be a difficult task, but it must be performed carefully and accurately due to general rules on the installation of wheel rims and special instructions by the manufacturer, applicable especially when installing light metal rims. The mechanic must tighten the rim by applying a precisely determined force that does not damage the bolts or rims and attaches the wheel properly. The work must be performed quickly. A quick and quality installation of wheels can be performed only with appropriate tools.



*Variously coloured impact sockets with plastic protection for pneumatic hammer*

Unior manufactures a complete set of tools for changing wheels, which we tested with our mechanic and evaluated its applicability.

### **PNEUMATIC TOOLS**

Modern car service workshops or tyre repair shops change car tyres with pneumatic tools, as manual changing would take up too much time. Unior offers several different pneumatic filter regulators and lubricators that are attached to the pneumatic compressor device. We used a pneumatic filter regulator and lubricator with two cups (lubricator and filter, functioning as a condensation cup), an installed pressure gauge and an oil flow regulator and indicator.

This pneumatic filter regulator and lubricator can also be used for various pneumatic tools. For the installation of wheels, we used the Unior pneumatic hammer, connected to the compression device via quick couplings and plugs and the use of the Unior spiral pneumatic hose. This connection is common in service workshops except that mechanics prefer a self-winding hose instead of a spiral hose, as it can get tangled after extended use.

Mechanics use the pneumatic hammer for the installation of rims, as it makes the work easier and quicker. The Unior pneumatic hammer is relatively powerful (678 NM) with a robust metal body. The metal body without additional protection (rubber or plastic) is the best solution according to our mechanic, as the hammer can be cleaned quickly, while any additional protection becomes damaged, dirty, greased, etc. when used.

### **IMPACT SOCKET, LONG TYPE**

We tested the pneumatic hammer with Unior long impact sockets, which allow tightening of bolts that are placed deep into the rim in some

car brands. Impact sockets are equipped with a plastic protection to prevent the metal part from damaging the aluminium rim. As the plastic protections will sooner or later get damaged, they can be purchased separately!

Because of deep and narrow bolt holes in aluminium rims, the impact sockets must be relatively thin. According to our mechanic, these sockets get "tired" after extended use and can break due to their thin shape. Impact sockets for pneumatic tools are therefore not a "permanent" tool in the mechanical workshop. The Unior set includes impact sockets in three sizes (17, 19 and 21 mm), each equipped with a plastic protection in different colours, allowing the mechanic to select the appropriate socket by its colour.

### **WHAT TIGHTENING FORCE TO APPLY?**

When the work with the pneumatic tools is completed, the bolts must be tightened with a precisely determined force. This is one of the most important tasks in the installation of wheels, which must be performed accurately. Relying on your feeling when tightening the bolts can result in an insufficiently attached wheel or damaged bolt due to excessive tightening force. For passenger cars, a torque force of 110 to 120 Nm must be used for the final tightening of the bolts, while for multi-purpose vehicles the torque force is 200 Nm. For the final tightening of the bolts, Unior offers two torque wrenches: a slipper torque wrench and a pre-set torque wrench, which is factory calibrated. According to our mechanic, the pre-set torque wrench (with factory calibrated torque) is especially suitable for the installation or removal of wheels in workshops. He even suggests that every driver should keep this wrench (together with a relevant impact socket) in his/her vehicle, as it allows the removal of a flat tyre during the journey or accurate tightening of the bolts on the spare tyre (and easy unscrewing due to a large handle).



The following Unior tools were used for the installation of wheels: pneumatic filter regulator and lubricator, pneumatic hammer, impact wrenches, slipper and pre-set torque wrenches, couplings and plugs, tools for tyre valves and wheel balancing pliers.

**TOOLS USED:**

**Pneumatic reversible hammer 1/2" - 1562**

- free speed 7000 revolution per minutes
- max. torque 949 Nm
- maximum air pressure : 6,2 Bar
- air consumption 119 l/min

**Pneumatic filter regulator and lubricator 3/4" - 1503**

- maximum air pressure : 9,5 Bar
- working pressure 0,5 - 8,5 Bar
- air consumption 2500 l/min
- filter capacity 60ml
- lubricator capacity 90ml

**Set of 1/2" impact sockets for alloy wheels in plastic box - 231/4PPB**

- material: chrome molybdenum
- surface finish: phosphated to standard DIN 12476
- with plastic protection

**Slipper torque wrench 1/2" - 263A**

- Accuracy: +/-3%
- micrometer scale for simple and error free settings
- adjustment lock to set torque
- Torque application: bothway, but always apply in direction specified on torque wrench handle
- The default calibration interval of the torque wrench is 12 months or 5.000 measurements from the date of end user purchase.

**Pre-set torque wrenches for cars - 267A**

- material: chrome vanadium
- factory calibrated for accuracy to within +/-4%



1503

263A

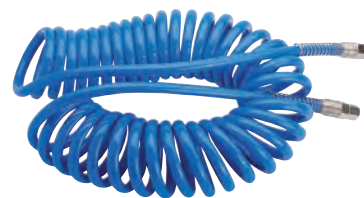

1505



1562



231/4PPB



1572

**Pneumatic reversible hammer 3/4"**

- free speed 5500 revolution per minutes
- max. torque 1491 Nm
- maximum air pressure : 6,2 Bar
- air consumption 269 l/min
- air inlet 3/8"
- max bolt size M30

**Advantages:**

- controlled torque
- fast screwing
- wide range of use

**Usage**

- car industry
- aircraft industry
- agricultural equipment
- heavy industry
- larger construction machinery
- shipbuilding industry
- individual mounting

**Important!**

- Always use Unior IMPACT sockets.

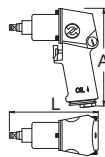

615323	3/4"	235	220	1491	6440	TF	1
--------	------	-----	-----	------	------	----	---

1591

**Pneumatic reversible hammer 1"**

- free speed 4000 revolution per minutes
- max. torque 2439 Nm
- maximum air pressure : 6,2 Bar
- air consumption 340 l/min
- air inlet 1/2"
- max bolt size M36

**Advantages:**

- controlled torque
- fast screwing
- wide range of use

**Usage**

- car industry
- aircraft industry
- agricultural equipment
- heavy industry
- larger construction machinery
- shipbuilding industry
- individual mounting

**Important!**

- Always use Unior IMPACT sockets.

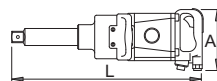
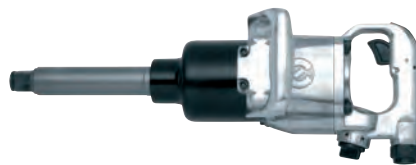

615325	1"	180	495	2439	13600	TF	1
--------	----	-----	-----	------	-------	----	---

1592

**Pneumatic reversible hammer 1"**

- free speed 4000 revolution per minutes
- max. torque 2439 Nm
- maximum air pressure : 6,2 Bar
- air consumption 340 l/min
- air inlet 1/2"
- max bolt size M36

**Advantages:**

- controlled torque
- fast screwing
- wide range of use

**Usage**

- car industry
- aircraft industry
- agricultural equipment
- heavy industry
- larger construction machinery
- shipbuilding industry
- individual mounting

**Important!**

- Always use Unior IMPACT sockets.

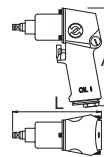

615326	1"	280	307	2439	12800	TF	1
--------	----	-----	-----	------	-------	----	---

1596

**Pneumatic reversible hammer 1.1/2"**

- free speed 3000 revolution per minutes
- max. torque 3388 Nm
- maximum air pressure : 6, 2 Bar
- air consumption 410 l/min
- air inlet 1/2"
- max bolt size M45

**Advantages:**

- controlled torque
- fast screwing
- wide range of use

**Usage**

- car industry
- aircraft industry
- agricultural equipment
- heavy industry
- larger construction machinery
- shipbuilding industry
- individual mounting

**Important!**

- Always use Unior IMPACT sockets.

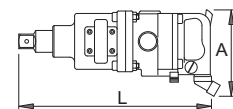
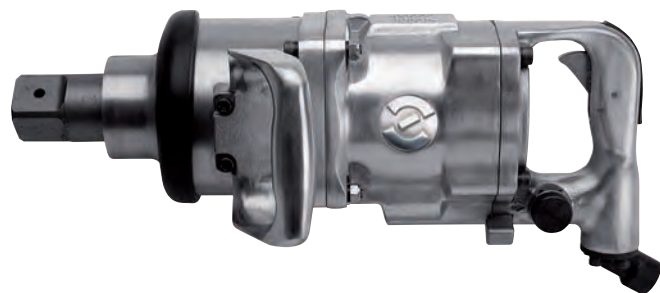

617690	1.1/2"	145	450	3388	17800	TF	1
--------	--------	-----	-----	------	-------	----	---

**1597**

**Pneumatic reversible hammer 1.1/2"**

- free speed 3000 revolution per minutes
- max. torque 4065 Nm
- maximum air pressure : 6, 2 Bar
- air consumption 435 l/min
- air inlet 1/2"
- max bolt size M52

**Advantages:**

- controlled torque
- fast screwing
- wide range of use

**Usage**

- car industry
- aircraft industry
- agricultural equipment
- heavy industry
- larger construction machinery
- shipbuilding industry
- individual mounting

**Important!**

- Always use Unior IMPACT sockets.

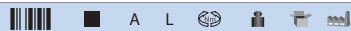
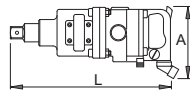

617691 1.1/2" 145 465 4065 18600 1E 1

**1514.1**

**Spring for 1514**



617716 69 1E 1

**1514.2**

**Quick change retainer for 1514**

- for fast and simple attachment/removing of the chisel
- quick replacement with releasing the upper releasing ring
- ribbed releasing ring for maximum grip when replacing



617717 351 1E 1

**1514**

**Stroke pneumatic hammer**

- used for cutting sheet, bolts and removing welding slag, rivets, plaster and tiles
- with spring, quick change retainer as spare parts
- piston stroke length: 170 - 67mm, 225 - 92mm
- bore diameter 9,1mm
- stroke per minute: 170 - 3000, 225 - 2100
- air consumption 250 l/min
- air inlet 1/4"

**Advantages:**

- light and compact tool, used also in small rooms
- wide range of use
- change retainer

**Usage**

- car industry
- cutting of sheet metal and screws
- removal of welds
- working on walls, concrete, stones, bricks, steel, light metals

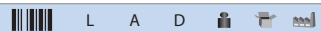
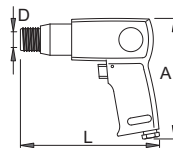

617714 170 150 19 1810 1E 1

617715 225 150 19 2160 1E 1

**1514A1**

**Flat chisel**

**Usage**

- Shaping and cleaning of welds, trimming of bolts and nails, production of slots, cleaning and evening of uneven surfaces.

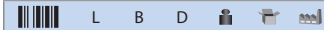
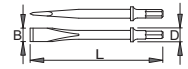

617718 182 18 19 181 1E 1

**1514A2**

**Pointed chisel**

**Usage**

- removing pins and rivets, making holes

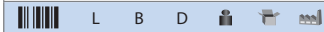
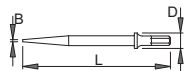

617719 180 2 19 154 1E 1

**1514A3**

**Rivet and welding slag chisel**

**Usage**

- removing rivets and welding slags

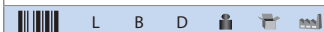
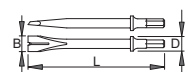

617720 180 20 19 179 1E 1

**1514A4**

**Sheet cutting chisel**

**Usage**

- cutting sheet metal

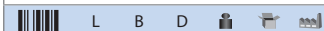
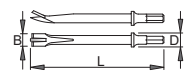

617721 180 16.7 19 178 1E 1

**1514A5**

**V edge chisel**

**Usage**

- cutting sheet metal





617722	L	B	D	1E	1
617722	190	19.2	19	187	1

**1514A6**

**Spade chisel**

**Usage**

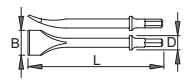
- shaping and cleaning of welds, trimming of bolts and nails, production of slots, cleaning and evening of uneven surfaces





617723	L	B	D	1E	1
617723	178	32.8	19	207	1

**1514PB**

**Stroke pneumatic hammer, with set of chisels**

- Dimension of box: 307 x 260 x 70



619964	7	3210	1G	1
--------	---	------	----	---

1514 (170), 1514A1 (182), 1514A2 (180), 1514A3 (180), 1514A4 (180), 1514A5 (190), 1514A6 (178), 981PBM2 (307 x 260 x 74)

**1510**

**1510**

**Pneumatic sander**

- free speed 10000 revolution per minutes
- maximum air pressure : 6,2 Bar
- air consumption 212 l/min
- air inlet 1/4"
- velcro sander pad

**Advantages:**

- the ergonomic shape of the handle enables good grip and prevents gliding
- suitable for lefthanders as well as for right-handers
- silent and powerful drive
- handy on/off switch
- exhaustion of parts into a bag for a cleaner workplace
- flexible and robust pipe for cleaning dust
- it does not leave edges on the working platform
- better work conditions due to minimal vibrations
- extreme power based on its weight (1.2 kg)

**Usage**

- vehicle workshops
- preparation of different working platforms for further process
- ideal for grinding construction steel, metals and wood
- The basis of sander is VELCRO™ system which is: quick, simple and safe to mount and unmount various sander pads. This system is being used for various occasions - the best known example is training shoes with VELCRO™ fastening.

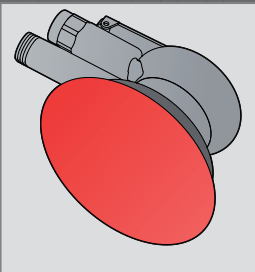

Velcro sander pad.

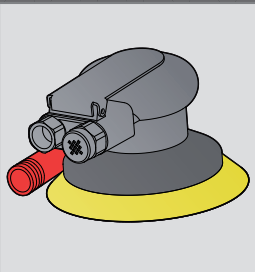

Exhaustion of parts into a bag for a cleaner workplace.

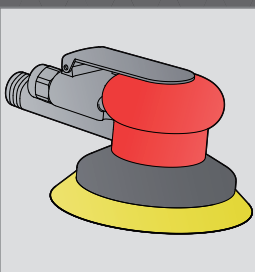

The ergonomic shape of the handle enables good grip and prevents gliding.

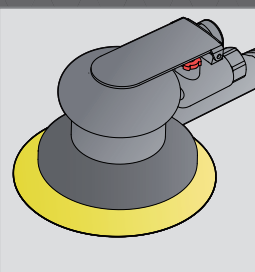

Handy on/off switch.



**1510**

**Pneumatic sander**



- free speed 10000 revolution per minutes
- maximum air pressure : 6,2 Bar
- air consumption 212 l/min
- air inlet 1/4"
- velcro sander pad

**Advantages:**

- the ergonomic shape of the handle enables good grip and prevents gliding
- suitable for lefthanders as well as for right-handers
- silent and powerful drive
- handy on/off switch
- exhaustion of parts into a bag for a cleaner workplace
- flexible and robust pipe for cleaning dust
- it does not leave edges on the working platform
- better work conditions due to minimal vibrations
- extreme power based on its weight (1.2 kg)

**Usage**

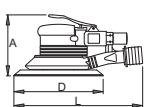
- vehicle workshops
- preparation of different working platforms for further process
- ideal for grinding construction steel, metals and wood
- The basis of sander is VELCRO™ system which is: quick, simple and safe to mount and unmount various sander pads. This system is being used for various occasions - the best known example is training shoes with VELCRO™ fastening.

617733	Nº	L	A	D	1E	1
617733	2.5	220	105	150	1600	1
617713	5	220	105	150	1615	1

1516

**Pneumatic die grinder**

- free speed 25000 revolution per minutes
- maximum air pressure : 6, 2 Bar
- air consumption 113 l/min
- air inlet 1/4"
- collet capacity 6 mm
- internal hose size 10mm

**Advantages:**

- safety lever which prevents accidental turn-on
- simple clamping of thin cut-off wheels(grinding/polishing pins) and other parts/extensions
- extreme power based on size
- small and compact tool
- continuously variable regulation of rpm

**Usage**

- precise grinding
- full grinding
- tool industry
- car industry
- aircraft industry
- cleaning of welds
- cleaning of concrete and wall surfaces
- cleaning of wooden surfaces
- removal of colors and varnish
- removal of rust
- grinding of bearings
- grinding of motor valves
- grinding of gears and coils
- various other surfaces

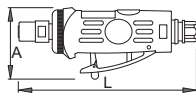

	L	A			
617731	155	60	390	TF	1

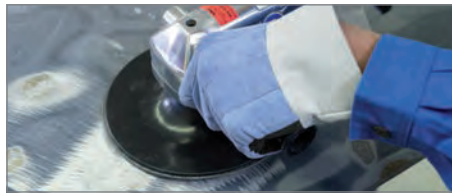

1516A

**Pneumatic angle die grinder**

- free speed 20000 revolution per minutes
- maximum air pressure : 6, 2 Bar
- air consumption 113 l/min
- air inlet 1/4"
- collet capacity 6 mm
- internal hose size 10mm

**Advantages:**

- this angle edition enables access to difficult-to-reach places which normal grinders cannot reach
- safety lever which prevents accidental turn-on
- simple clamping of thin cut-off wheels(grinding/polishing pins) and other parts/extensions
- extreme power based on size
- small and compact tool
- continuously variable regulation of rpm

**Usage**

- precise grinding
- full grinding
- tool industry
- car industry
- aircraft industry
- cleaning of welds
- cleaning of concrete and wall surfaces
- cleaning of wooden surfaces
- removal of colors and varnish
- removal of rust
- grinding of bearings
- grinding of motor valves
- grinding of gears and coils
- various other surfaces

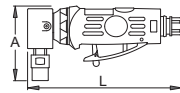

	L	A			
617732	162	76	740	TF	1



1517S

**Pneumatic angle sander**

- free speed 4500 revolution per minutes
- maximum air pressure : 6, 2 Bar
- air consumption 340 l/min
- air inlet 1/4"
- spindle thread 5/8"

**Advantages:**

- small and compact tool
- suitable for lefthanders as well as for right-handers
- removable handle
- handy turn-on switch

**Usage**

- grinding of welds
- grinding of sharp edges
- repairation of small uneven surfaces

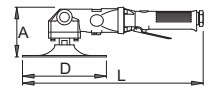

	L	A	D			
617729	375	100	175	2610	TF	1

1518

**Pneumatic angle grinder**

- free speed 11000 revolution per minutes
- maximum air pressure : 6, 2 Bar
- air consumption 170 l/min
- air inlet 1/4"

**Advantages:**

- removable handle
- safety lever prevents unwanted turn-on

**Usage**

- protection from rotating parts
- also usable in small rooms/places
- tool industry
- cleaning of welds
- cleaning of concrete and wall surfaces
- cleaning of wooden surfaces
- removal of colors and varnish
- removal of rust
- cutting profile carriers and sheet metal
- other home use

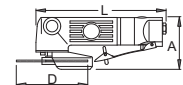

	L	A	D			
617730	230	90	125	2175	TF	1

**1515**

**Pneumatic drill**

- reversible
- free speed 1800 revolution per minutes
- maximum air pressure : 6, 2 Bar
- air consumption 113 l/min
- air inlet 1/4"
- chuck capacity 1,0 - 10mm
- spindle thread 3/8", 24 UNF
- internal hose size 10mm



**Advantages:**

- extreme power based on size
- lightweight, compact and easy-to-master tool
- handy turn-on switch
- ergonomically shaped handle for work without effort
- plastic cover for handle dampens vibrations
- reversible turning
- quick change retainer

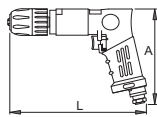

617726	190	150	1360	1E	1
--------	-----	-----	------	----	---

**1515H**

**Pneumatic drill with handle**

- reversible turning
- free speed 800 revolution per minutes
- maximum air pressure : 6, 2 Bar
- air consumption 113 l/min
- air inlet 1/4"
- chuck capacity 1,5 - 13mm
- spindle thread 3/8", 24 UNF
- internal hose size 10mm



**Advantages:**

- extreme power based on size
- lightweight, compact and easy-to-master tool
- adjustable handle for better support
- handy turn-on switch
- ergonomically shaped handle for work without effort
- plastic cover for handle dampens vibrations
- reversible turning
- quick change retainer

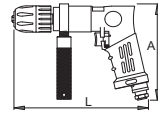
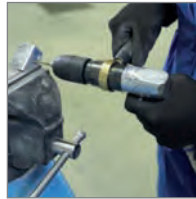

617727	220	150	1570	1E	1
--------	-----	-----	------	----	---

**1500**

**Pneumatic filter regulator and lubricator 1/4"**

- air inlet 1/4"
- maximum air pressure : 9,5 Bar
- air consumption 600 l/min
- working pressure 0,5 - 8,5 Bar
- working temperature 5 - 60 °C
- filtering grade 5µ
- filter capacity 15ml
- lubricator capacity 25ml

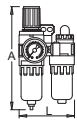

617735	90	155	491	1E	1
--------	----	-----	-----	----	---

**1500C**

**Cups set for 1500**



617738	71			1E	1
--------	----	--	--	----	---

**1508A**

**Pneumatic duster**

- maximum air pressure : 10,9 Bar
- air consumption 220 l/min

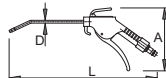

617767	260	135	6	153	1E	10
--------	-----	-----	---	-----	----	----

**1508B**

**Long pneumatic duster**

- maximum air pressure : 10,9 Bar
- air consumption 220 l/min

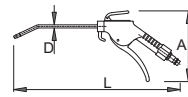

617768	420	135	6	178	1E	10
--------	-----	-----	---	-----	----	----

**1501**

**Pneumatic filter regulator and lubricator 3/8"**

- air inlet 3/8"
- maximum air pressure : 9,5 Bar
- air consumption 1800 l/min
- working pressure 0,5 - 8,5 Bar
- working temperature 5 - 60 °C
- filtering grade 5µ
- filter capacity 60ml
- lubricator capacity 90ml

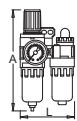

617736	150	220	1285	1E	1
--------	-----	-----	------	----	---

### 1501C

#### Cups set for 1501 and 1502



617739	175	TE	1
--------	-----	----	---

### 1502

#### Pneumatic filter regulator and lubricator 1/2"

- air inlet 1/2"
- maximum air pressure : 9,5 Bar
- working pressure 0,5 - 8,5 Bar
- working temperature 5 - 60 °C
- filtering grade 5µ
- air consumption 2300 l/min
- filter capacity 60ml
- lubricator capacity 90ml

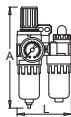

617737	L 150	A 220	1265	TE	1
--------	-------	-------	------	----	---

### 1503

#### Pneumatic filter regulator and lubricator 3/4"

- air inlet 3/4"
- maximum air pressure : 9,5 Bar
- working pressure 0,5 - 8,5 Bar
- working temperature 5 - 60 °C
- filtering grade 5µ
- air consumption 2500 l/min
- filter capacity 60ml
- lubricator capacity 90ml

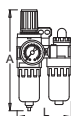

621473	L 190	A 240	1805	TE	1
--------	-------	-------	------	----	---

### 1500PG

#### Pressure gauge for 1500



617741	63	TF	1
--------	----	----	---

### 1501PG

#### Pressure gauge for 1501 in 1502



617742	16	TF	1
--------	----	----	---

### 1505

#### Spiral pneumatic hose

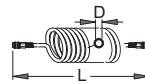
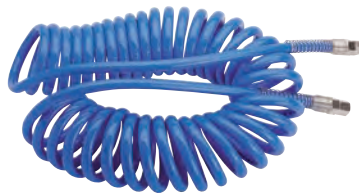

617743	L (m)	D	850	TE	1
617744	9	6.5 x 10	850	TE	1
617745	9	8 x 12	894	TE	1
617746	9	11 x 16	1526	TE	1
617747	12	6.5 x 10	835	TE	1
617747	12	8 x 12	1076	TE	1
617748	12	11 x 16	1847	TE	1

### 1506PZ

#### Coupling, female part

- plastic housing
- outside thread

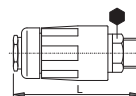

617788	R1/4"	19	72	133	TE	1
617789	R3/8"	19	70	137	TE	1
617790	R1/2"	22	75	145	TE	1

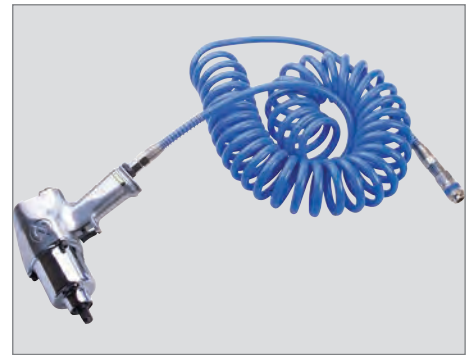

### 1506KZ7

#### Coupling, female part

- metal housing
- outside thread

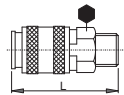

617793	R1/4"	20	58	98	TE	1
617794	R3/8"	20	54	101	TE	1

### 1506KZ10

#### Coupling, female part

- metal housing
- outside thread

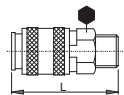

621452	3/8"	24	62.5	149	TE	1
621453	1/2"	24	65.0	156	TE	1
621454	3/4"	27	67.1	191	TE	1

### 1506KN7

#### Coupling, female part

- metal housing
- inside thread

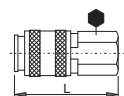

617795	R1/4"	20	54.5	113	TE	1
617796	R3/8"	20	55	105	TE	1



**1507Z7**

**Coupling, male part**

- inside hose diameter  $\varnothing 7\text{mm}$
- outside thread

Barcode	Size	L	D	W	Weight	Material	Quantity
617797	R1/4"	14	34	24	1E	1	1
617798	R3/8"	19	36.5	34	1E	1	1
618483	R1/2"	22	39	40	1E	1	1

**1507Z10**

**Coupling, male part**

- outside thread
- inside hose diameter  $\varnothing 10\text{mm}$

Barcode	Size	L	D	W	Weight	Material	Quantity
621455	3/8"	17	39.4	38	1E	1	1
621456	1/2"	24	39.4	53	1E	1	1
621457	3/4"	27	48.5	86	1E	1	1

**OP1.4/2**

**Hanger for pneumatic tools with 1/4" air inlet**

Barcode	Weight	Material	Quantity
623315	110	1V	1

**650.1/6**

**Flat colt chisel SDS plus**

Barcode	L	D	b	Weight	Material	Quantity
616831	250	14	20	260	4B	10

**651.1/7**

**Flat colt chisel SDS max**

Barcode	L	D	b	Weight	Material	Quantity
616835	280	18	25	507	4B	10
616836	400	18	25	740	4B	5
616837	600	18	25	1133	1E	5

**650.2/6**

**Pointed chisel SDS plus**

Barcode	L	D	Weight	Material	Quantity
616832	250	14	246	4B	10

**651.2/7**

**Pointed chisel SDS max**

Barcode	L	D	Weight	Material	Quantity
616838	280	18	482	4B	10
616839	400	18	717	4B	5
616840	600	18	1105	1E	5

**650.3/6**

**Grooving chisel SDS plus**

Barcode	L	D	b	Weight	Material	Quantity
616833	250	16	22	347	4B	10

**651.3/7**

**Grooving chisel SDS max**

Barcode	L	D	b	Weight	Material	Quantity
616842	300	18	26	518	4B	5

**650.4/6**

**Spade chisel SDS plus**

Barcode	L	D	b	Weight	Material	Quantity
616834	250	16	40	351	4B	10

**651.4/7**

**Spade chisel SDS max**

Barcode	L	D	b	Weight	Material	Quantity
616841	300	18	80	729	4B	5

# IRONGATOR ENGINEER'S VICE

## Why do you need a reliable vice in a car repair shop?

A vice is a basic tool for every workshop that should, despite its robustness, also be maintained to ensure long-term use. It needs to be cleaned at least once a week.

The easiest way to repair various car components is to clamp them in an engineer's vice that is usually affixed to the workbench. There are several types of vices, however our mechanic recommends that in addition to a more robust engineer's vice, your workshop should also include a slightly lighter vice with quick moving jaws.



*The vice with quick moving system is a tool that should be in every workshop.*

Every vice has a movable and fixed jaw, a threaded spindle and an impact surface. The basic version of a robust vice has a protected spindle (in a tube) to prevent its damage. In good vices, the lower part of the spindle is designed to allow clamping of tubes. In a robust engineers vice, the jaws are very strong and allow tightening of parts for processing with great force. This vice (its sliding surfaces) is constructed in such a manner to withstand strong impacts on the impact surface without any damage. The jaws are made of solid steel and can also be replaced in the event of damage. To prevent damage to the clamped softer material, you can cover the jaws with plastic or metal plates made of mild steel, aluminium or lead.

In recent years, the engineer's vice with a quick moving system is becoming an indispensable tool. Our mechanic claims that this vice is an extremely practical and useful tool and recommends every mechanic to get one for his workshop.

Unior has developed this tool anew, collaborating with the University of Maribor in the development of the quick travel and using a similar solution to the quick travels used on lathes.

Quick travel enables fast moving of the jaws according to the size of the piece for clamping. This is achieved by moving the guide for precise running of the moving parts of the vice. When you move the moving jaw towards the clamped piece, you should turn the spindle handle a half a turn (or less for releasing) for a final firm grip. In this way, the time used for bringing the jaws together by turning the handle in regular vices is significantly reduced, and the task is also easier, since the mechanic does not require any assistance with the clamping. This excellent tool has all the characteristics of regular vices, including the tube grip, and is also suitable for slightly smaller loads than with the most robust vices.

Both vices can also be installed on a swivel base, which can be used to change the position: the base is firmly screwed on the workbench, while the vice is attached to the swivel base, which enables turning. This solution will delight mechanics who perform a great deal of tube processing works (plumbing, central heating etc.), while in a car repair shop there is no great need for the installation of the swivel base.

Even though engineers' vices are a robust and heavy tool that can withstand great loads, they must be cleaned after use. In the past, mechanics ordered their apprentices to clean the vices in the workshop every weekend in the event of normal use to prevent fillings from wearing down the spindle. In a robust vice, the spindle is protected by a tube, however the spindle in a vice with a quick moving system is exposed and regular cleaning is necessary. It is also advisable to occasionally slightly lubricate the spindle with oil.

## TOOLS USED:

### Quick IRONGATOR engineer's vice with quick moving system - 721Q/6

- housing from gray iron casting
- drop forged jaws from tool carbon steel, hardened and tempered
- lacquered housing, jaws anticorrosive oiled, other parts zinc plated
- uniPRO slides ensure precise running of moving parts
- engineer's vice can be combined with swivel base

### IRONGATOR engineer's vice - 721/6

- housing from gray iron casting
- drop forged jaws from tool carbon steel, hardened and tempered
- lacquered housing, jaws anticorrosive oiled, other parts zinc plated
- spindle protected against damage
- engineer's vice can be combined with swivel base

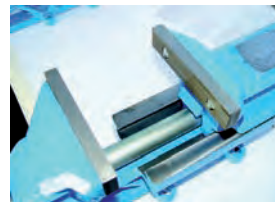
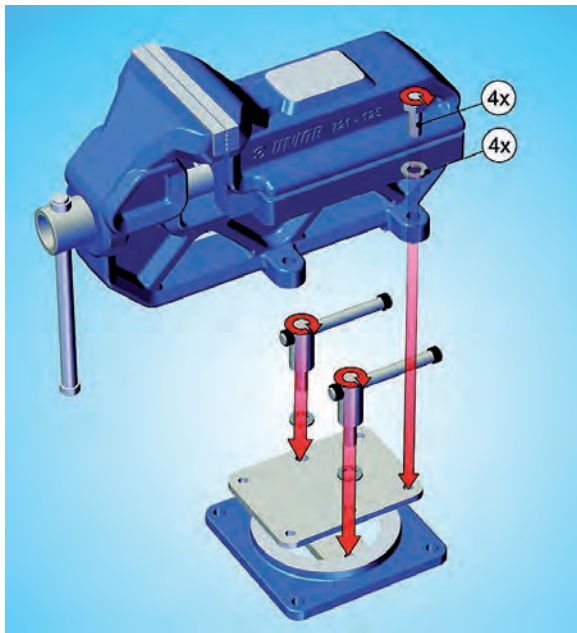

*Spindles in robust vices are protected by a tube.*

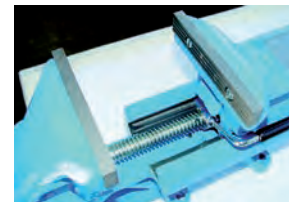

*Vice with quick moving system is equipped with a guide for precise running.*

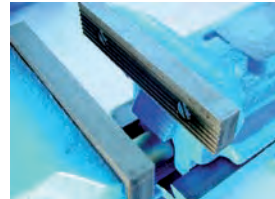

*Jaws are made of solid toothed steel.*



*The lower end of the jaw is designed for clamping of tubes.*



*The quick travel guide is raised and the jaw is moved without rotating the spindle.*



*The impact surface can withstand strong impacts.*



*For a firm grip, the spindle handle must be turned only by a half of the circle.*



*The vice with quick travel is also equipped with jaws for gripping tubes.*

721/6  
721Q/6

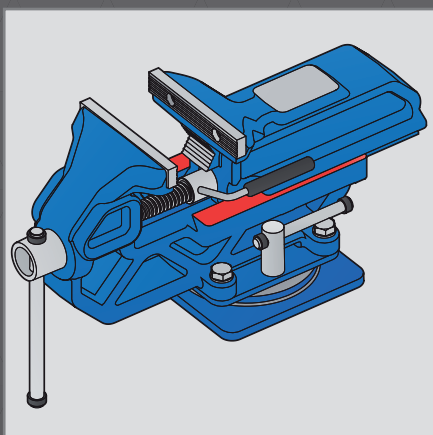
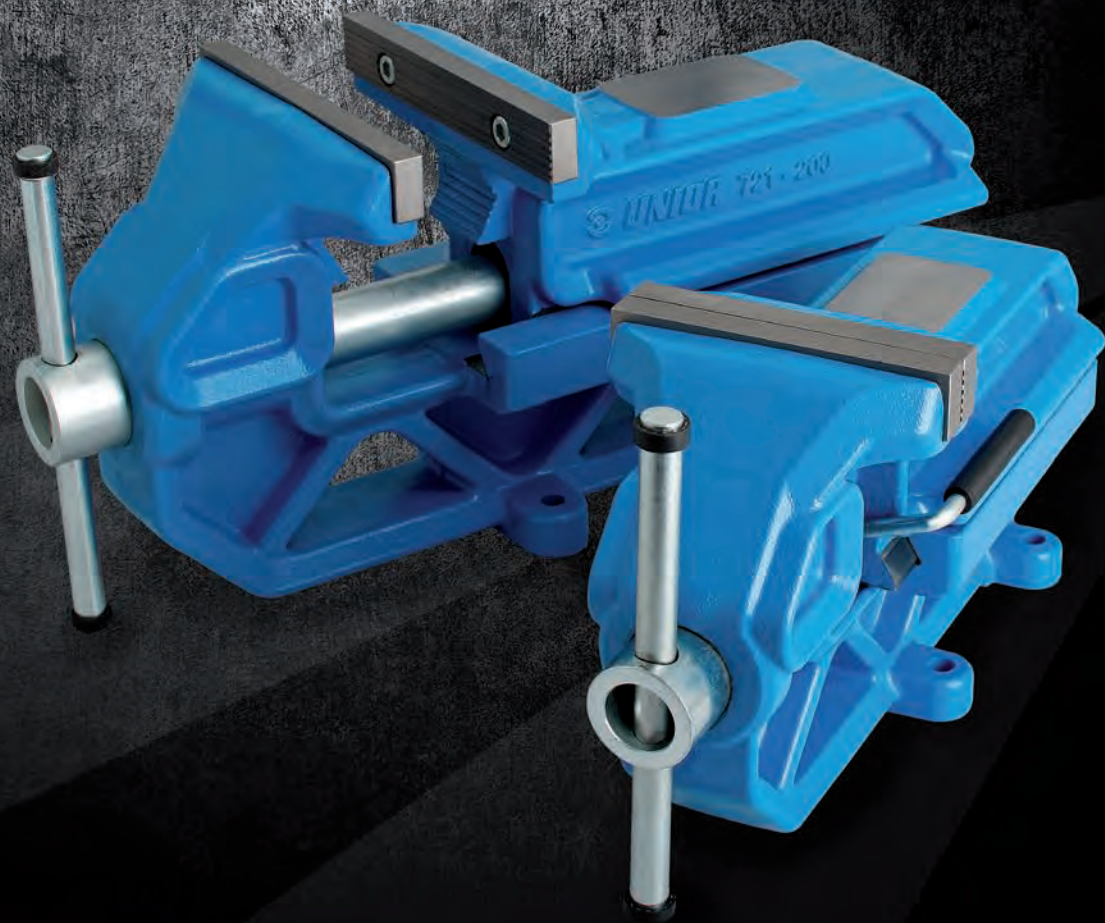

UniPRO slides ensure precise running of moving parts.

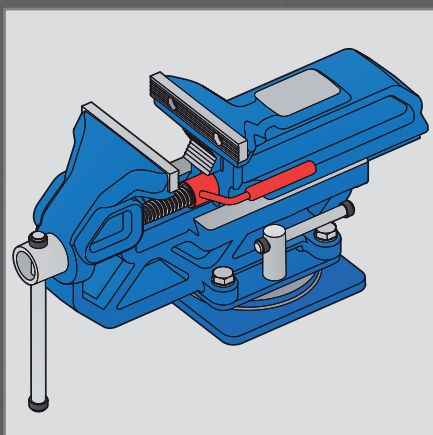

Quick moving system.

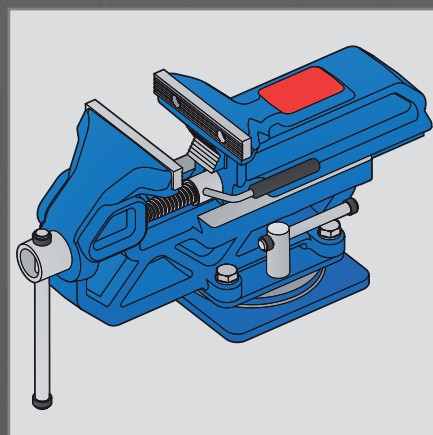

Grounded working place.

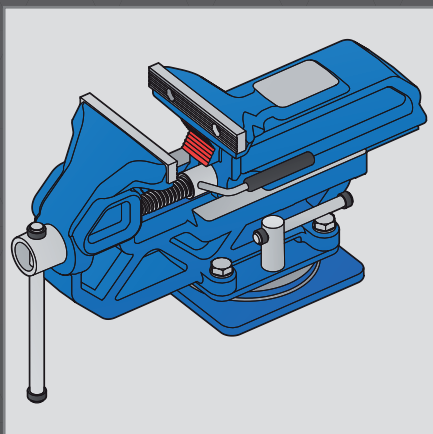

Fixed jaws for pipes holding.

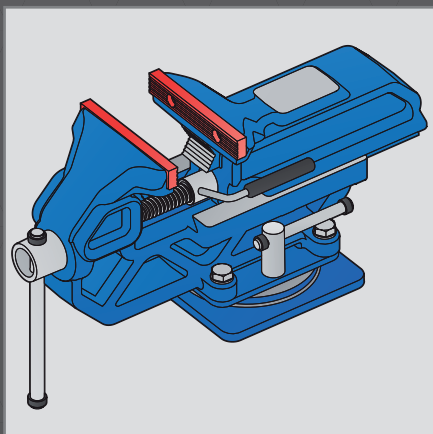

Drop forged jaws from tool carbon steel, hardened and tempered.

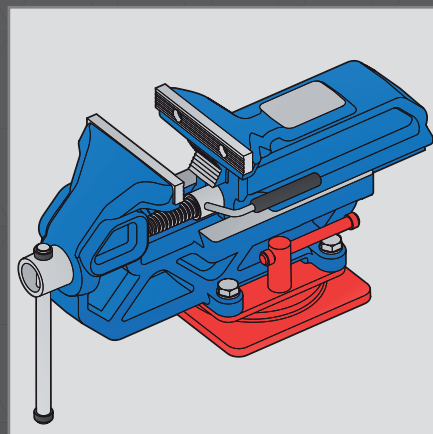

Swivel base can be rotated for 360°.

### 721/6

#### IRONGATOR engineer's vice

- housing from gray iron casting
- drop forged jaws from tool carbon steel, hardened and tempered
- lacquered housing, jaws anticorrosive oiled, other parts zinc plated
- spindle protected against damage
- uniPRO slides ensure precise running of moving parts
- engineer's vice can be combined with swivel base

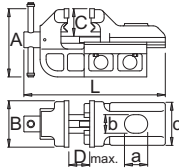

Barcode	B	D	L	U	C	a	b	c	A	Weight	Material	Quantity
621564	80	100	215	11-35	46	42	28	64	113	3500	IG	1
621481	125	160	336	17-62	73	66	44	95	176	14400	IG	1
621567	150	190	400	20-66	88	80	53	117	211	24200	IG	1
621570	200	220	461	24-80	103	93	62	140	265	37800	IG	1

### 721Q/6

#### Quick IRONGATOR engineer's vice with quick moving system

- housing from gray iron casting
- drop forged jaws from tool carbon steel, hardened and tempered
- lacquered housing, jaws anticorrosive oiled, other parts zinc plated
- uniPRO slides ensure precise running of moving parts
- engineer's vice can be combined with swivel base
- quick moving system

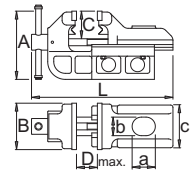

Barcode	B	D	L	U	C	a	b	c	A	Weight	Material	Quantity
621482	125	120	336	17-62	77	66	44	95	176	14500	IG	1
621568	150	190	400	20-66	88	80	53	117	211	23500	IG	1

### 721.1/6

#### Swivel base for 721/6 and 721Q/6

- housing from gray iron casting
- material other parts: special tool steel
- swivel base can be rotated for 360°



Barcode	Weight	Material	Quantity
621566	80	2570	1E 1
621483	125	2575	1E 1
621569	150	2580	1E 1
621572	200	2585	1E 1

### 722.1/7

#### Spare jaw for 721/6 and 721Q/6

- material: special tool steel
- drop forged, entirely hardened and tempered
- set 2 pieces



Barcode	B	Weight	Material	Quantity
623083	80	240	1E	1
619020	125	378	1E	1
619021	150	1030	1E	1
619023	200	1365	1E	1

### 722.1AL

#### Spare aluminium jaws for 721/6 and 721Q/6

- material: aluminium
- set 2 pieces



Barcode	B	Weight	Material	Quantity
623084	80	110	1E	1
619026	125	156	1E	1
619027	150	400	1E	1
619029	200	541	1E	1

